

**ПЛЪЗГАЩА
СИСТЕМА**

S28

**SLIDING
SYSTEM**

**ТЕХНИЧЕСКИ КАТАЛОГ
TECHNICAL CATALOGUE**



Плъзгаща система 28 мм (S28)



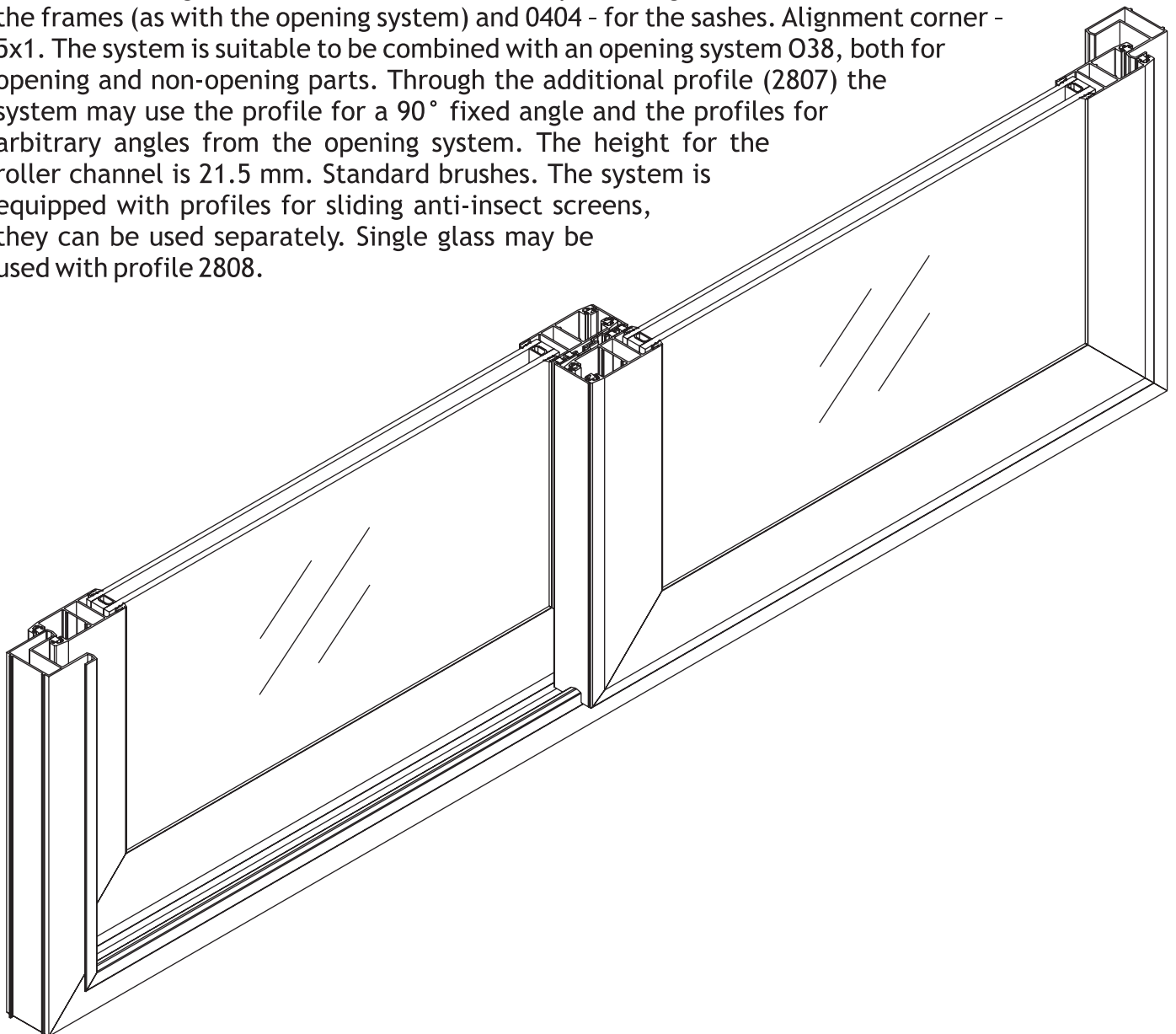

Система с ширина на крилото 28 мм, височина 61 мм и стъклопакет 20 мм. Системата има единична каса, двойна каса и тройна каса плъзгане. При касите се използва сглобка 0484S (както при отваряемата система), а при крилата 0404. Изравнителният ъгъл е 5x1. Системата има възможност много добре да се комбинира с отваряемата система O38, както за отваряеми, така и за неотваряеми части. Чрез специален допълнителен профил (2807) системата може да ползва от отваряемата система, както профилът за стационарен ъгъл 90°, така и профилите за произволни ъгли. Височината на канала за ролката е 21,5 мм. Четките са стандартни. Системата е окомплектована с профили за плъзгащи противонасекомни мрежи, които могат да се ползват и отделно. Чрез профил 2808 се дава възможност да се използва единично стъкло.

Sliding system 28 mm (S28)

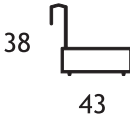
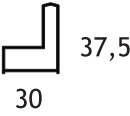
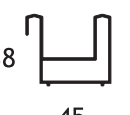
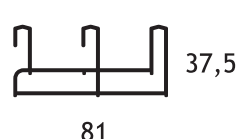
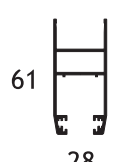
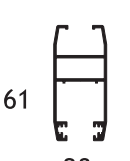
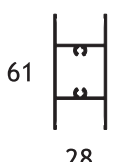
Width of the door sash - 28 mm, height - 61 mm and insulating glass unit - 20 mm. The system consists of a single frame, double frame and triple sliding frame. Corner 0484S is used for the frames (as with the opening system) and 0404 - for the sashes. Alignment corner - 5x1. The system is suitable to be combined with an opening system O38, both for opening and non-opening parts. Through the additional profile (2807) the system may use the profile for a 90° fixed angle and the profiles for arbitrary angles from the opening system. The height for the roller channel is 21.5 mm. Standard brushes. The system is equipped with profiles for sliding anti-insect screens, they can be used separately. Single glass may be used with profile 2808.

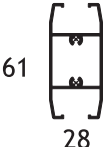
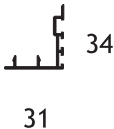

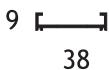
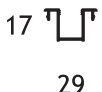
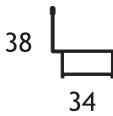
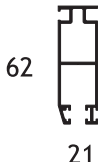
ПРОФИЛ PROFILE	Тегло Weight  (gr/m)	Инерционен момент Moments of inertia I_x J_Y (cm ⁴)		Външен Периметър Ext. Perimeter (mm)	Спецификация Specification	Повече на стр. MORE  (page)
		I_x	J_Y			
2801 	482	2,31	3,43	182	ЕДИНИЧНА КАСА FRAME	7
2814 	449	2,56	4,81	134	ЕДИНИЧНА КАСА FRAME	7
2802 	632	3,40	5,52	227	ДВОЙНА КАСА FRAME	7
2815 	1125	10,24	9,62	388	ТРОЙНА КАСА FRAME	8
2803 	737	8,42	3,58	333	КРИЛО SASH	8
2812 	776	8,44	3,67	353	КРИЛО SASH	8
2804 	695	6,57	3,20	241	ДЕЛИТЕЛ T-PROFILE	9

ПРОФИЛ PROFILE	Тегло Weight (gr/m)	Инерционен момент Moments of inertia		Външен Периметър Ext. Perimeter (mm)	Спецификация Specification	Повече на стр. MORE  (page)
		I_x (cm ⁴)	J_y			
2813 	482	6,62	3,36	182	ДЕЛИТЕЛ T-PROFILE	9
2805 	314	1,23	0,99	187	КАПАК ЗА КРИЛО HOOK	9
2806 	200	0,22	0,15	80	СРЕДЕН ПРОФИЛ SHOCK ABSORBER	10
2807 	217	0,05	1,47	121	СВЪРЗВАЩ ПРОФИЛ AD.PROFILE	10
2808 	232	0,31	0,56	143	СТЪКЛО- ДЪРЖАТЕЛ ЗА ЕДИНИЧНО СТЪКЛО ADJOINING PROFILE	11
2809 	385	1,50	1,98	144	КАСА ПРОТИВО- НАСЕКОМНА МРЕЖА SUPPL.FRA- ME PROFILE	11
2810 	699	10,81	1,70	307	КРИЛО ПРОТИВО- НАСЕКОМНА МРЕЖА FLY SCREEN SASH	12
2811 	509	4,01	1,07	155	ДЕЛИТЕЛ ПРОТИВО- НАСЕКОМНА МРЕЖА T-PROFILE	12

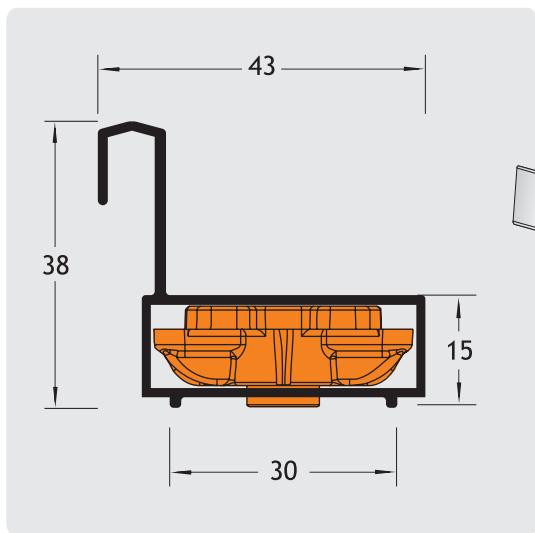

ЕДИНИЧНА КАСА FRAME	2801
ТЕГЛО / WEIGHT (gr/m)	W=482
Инерционен момент Moments of INERTIA (cm ⁴)	I _x =2,31
	J _y =3,43
Периметър / Perimeter (mm)	P=182
Акcesoари / Accessories	
сглобка / corner	0484S
израв. ъгъл/сглобка alignment corner	

ЕДИНИЧНА КАСА FRAME	2814
ТЕГЛО / WEIGHT (gr/m)	W=449
Инерционен момент Moments of INERTIA (cm ⁴)	I _x =2,56
	J _y =4,81
Периметър / Perimeter (mm)	P=134
Акcesoари / Accessories	
сглобка / corner	
израв. ъгъл/сглобка alignment corner	

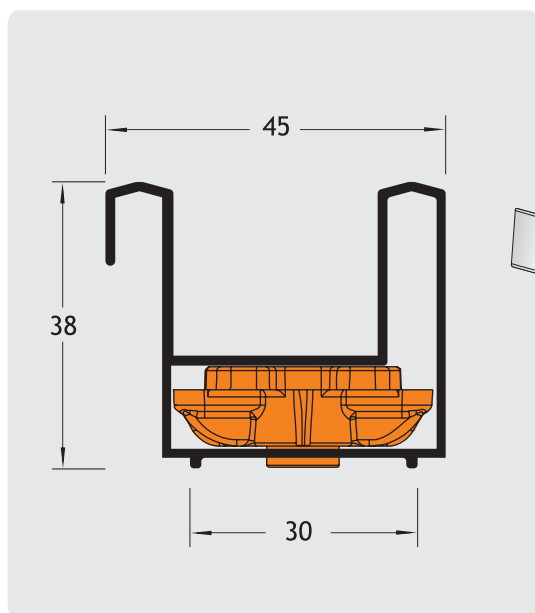
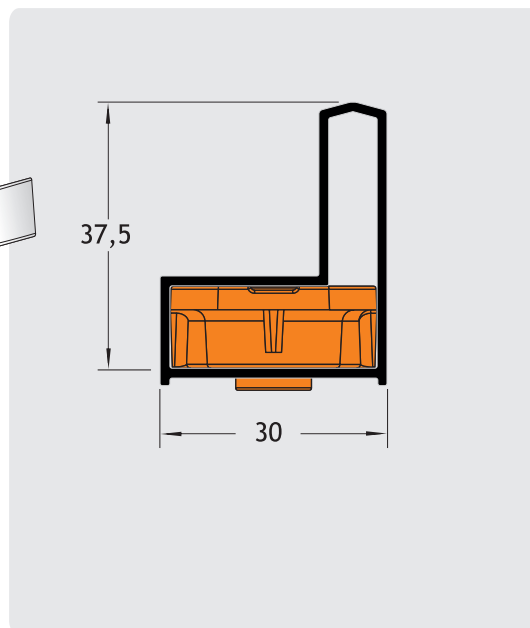

ДВОЙНА КАСА FRAME	2802
ТЕГЛО / WEIGHT (gr/m)	W=632
Инерционен момент Moments of INERTIA (cm ⁴)	I _x =3,40
	J _y =5,52
Периметър / Perimeter (mm)	P=227
Акcesoари / Accessories	
сглобка / corner	0484S
израв. ъгъл/сглобка alignment corner	

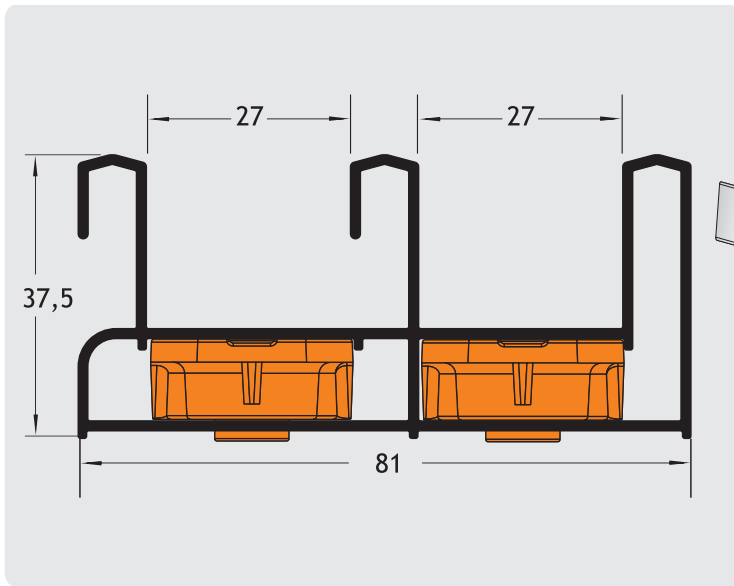

ТРОЙНА КАСА FRAME	2815
ТЕГЛО / WEIGHT (gr/m)	W=1125
Инерционен момент Moments of INERTIA (cm ⁴)	I _x =10,24
	J _y =9,62
Периметър / Perimeter (mm)	P=388
Акcesoари / Accessories	
сглобка / corner	0484S
израв. ъгъл/сглобка alignment corner	

КРИЛО SASH	2803
ТЕГЛО / WEIGHT (gr/m)	W=737
Инерционен момент Moments of INERTIA (cm ⁴)	I _x =8,42
	J _y =3,58
Периметър / Perimeter (mm)	P=333
Акcesoари / Accessories	
сглобка / corner	0404
израв. ъгъл/сглобка alignment corner	5x1

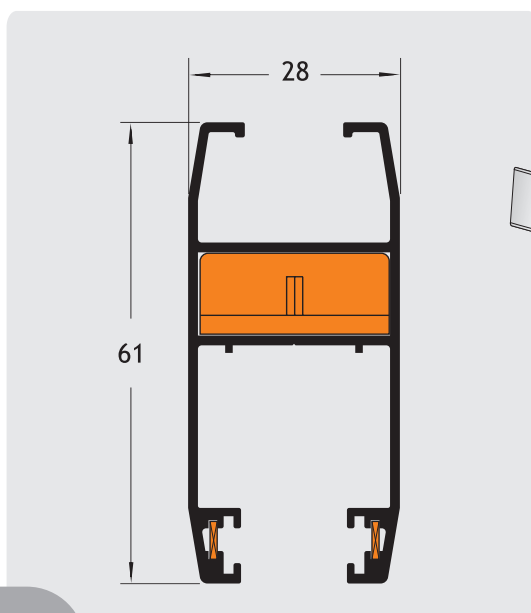
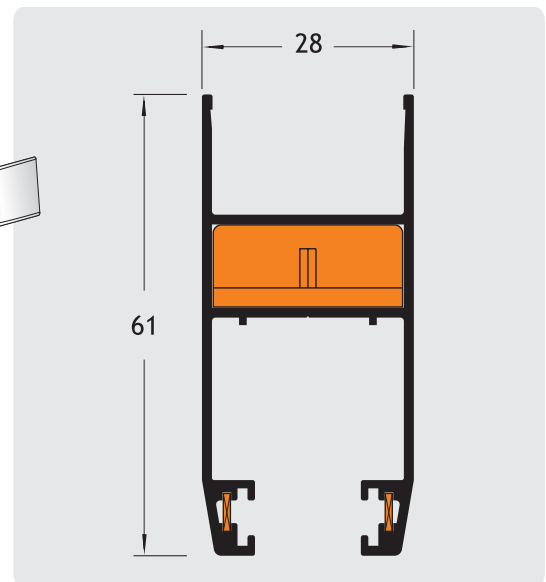

КРИЛО SASH	2812
ТЕГЛО / WEIGHT (gr/m)	W=776
Инерционен момент Moments of INERTIA (cm ⁴)	I _x =8,44
	J _y =3,67
Периметър / Perimeter (mm)	P=353
Акcesoари / Accessories	
сглобка / corner	0404
израв. ъгъл/сглобка alignment corner	

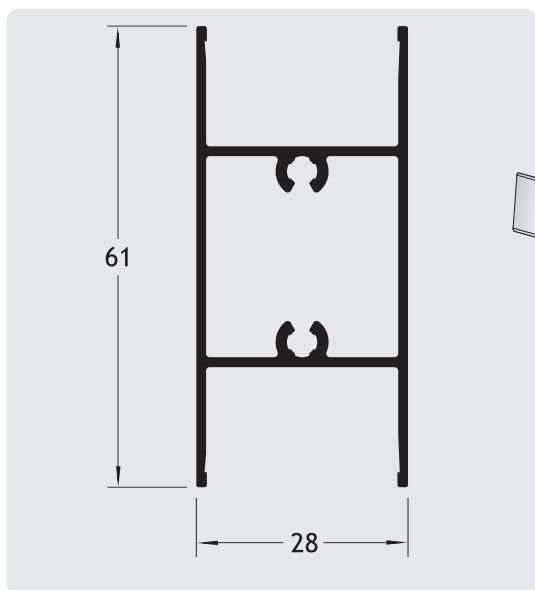

ДЕЛИТЕЛ T-PROFILE	2804
ТЕГЛО / WEIGHT (gr/m)	W=695
Инерционен момент Moments of INERTIA (cm ⁴)	I _x =6,57
	J _y =3,20
Периметър / Perimeter (mm)	P=241
Акcesoари / Accessories	
сглобка / corner	<input type="text"/>
израв. ъгъл/сглобка alignment corner	<input type="text"/>

ДЕЛИТЕЛ T-PROFILE	2813
ТЕГЛО / WEIGHT (gr/m)	W=482
Инерционен момент Moments of INERTIA (cm ⁴)	I _x =6,62
	J _y =3,36
Периметър / Perimeter (mm)	P=182
Акcesoари / Accessories	
сглобка / corner	<input type="text"/>
израв. ъгъл/сглобка alignment corner	<input type="text"/>

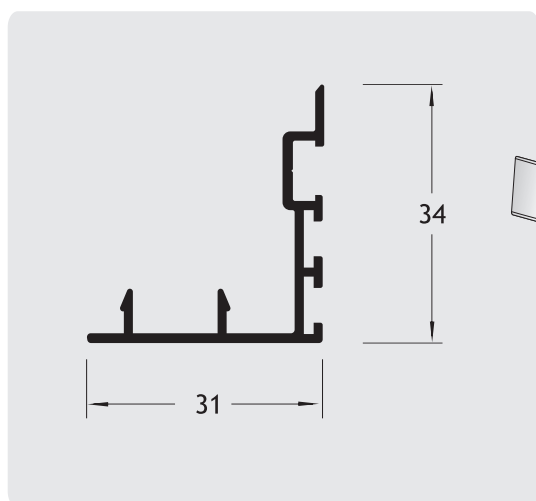
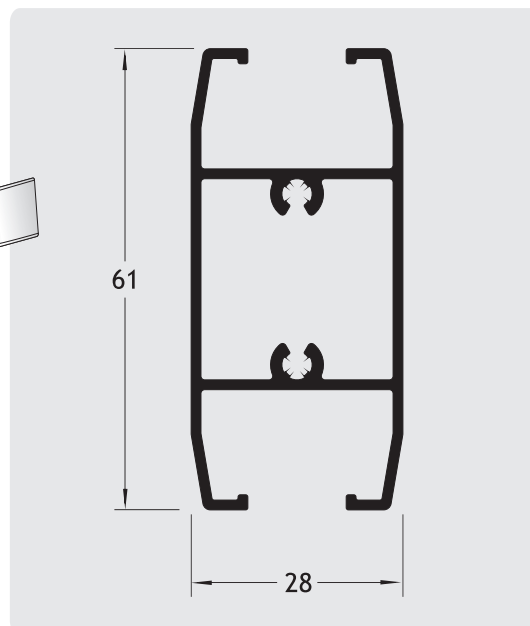

КАПАК ЗА КРИЛО HOOK	2805
ТЕГЛО / WEIGHT (gr/m)	W=314
Инерционен момент Moments of INERTIA (cm ⁴)	I _x =1,23
	J _y =0,99
Периметър / Perimeter (mm)	P=187
Акcesoари / Accessories	
сглобка / corner	<input type="text"/>
израв. ъгъл/сглобка alignment corner	<input type="text"/>

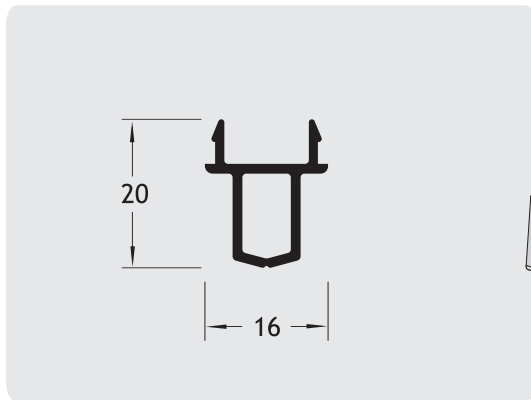

СРЕДЕН ПРОФИЛ SHOCK ABSORBER	2806
ТЕГЛО / WEIGHT (gr/m)	W=200
Инерционен момент Moments of INERTIA (cm ⁴)	I _x =0,22
	J _y =0,15
Периметър / Perimeter (mm)	P=80
Акcesoари / Accessories	
сглобка / corner	
израв. ъгъл/сглобка alignment corner	

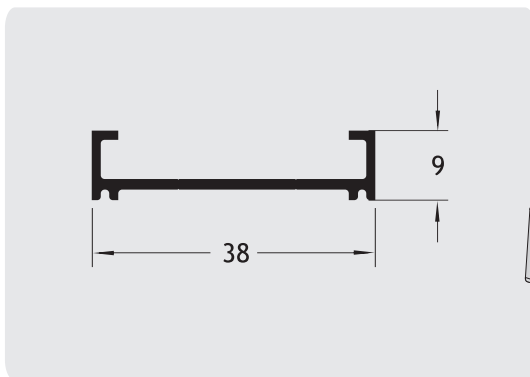

СВЪРЗВАЩ ПРОФИЛ ADJOINING PROFILE	2807
ТЕГЛО / WEIGHT (gr/m)	W=217
Инерционен момент Moments of INERTIA (cm ⁴)	I _x =0,05
	J _y =1,47
Периметър / Perimeter (mm)	P=121
Акcesoари / Accessories	
сглобка / corner	
израв. ъгъл/сглобка alignment corner	

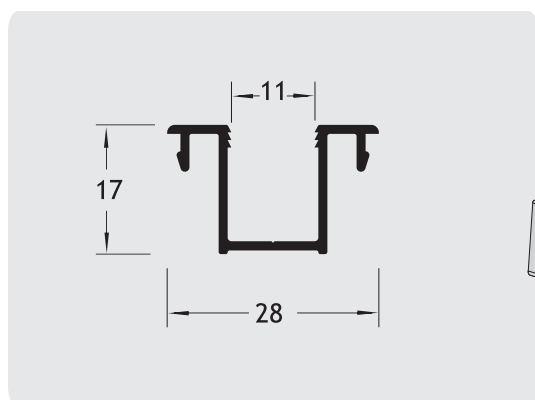

**СТЪКЛОДЪРЖАТЕЛ
ЗА ЕДИНИЧНО СТЪКЛО
ADJOINING PROFILE**

2808

ТЕГЛО / WEIGHT (gr/m) W=232

Инерционен момент
Moments of INERTIA
(cm⁴)

I_x=0,31

J_y=0,56

Периметър / Perimeter (mm) P=143

Акcesoари / Accessories

сглобка / corner

израв. ъгъл/сглобка
alignment corner

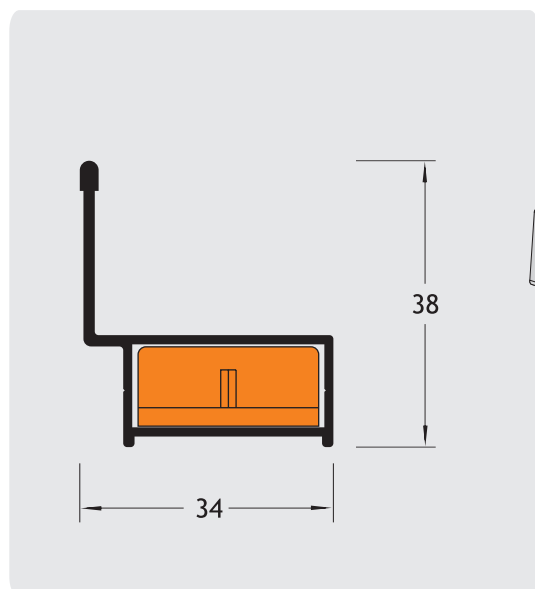

**КАСА ПРОТИВО-
НАСЕКОМНА МРЕЖА
SUPPLEM. PROFILE**

2809

ТЕГЛО / WEIGHT (gr/m) W=385

Инерционен момент
Moments of INERTIA
(cm⁴)

I_x=1,50

J_y=1,98

Периметър / Perimeter (mm) P=144

Акcesoари / Accessories

сглобка / corner

0404

израв. ъгъл/сглобка
alignment corner

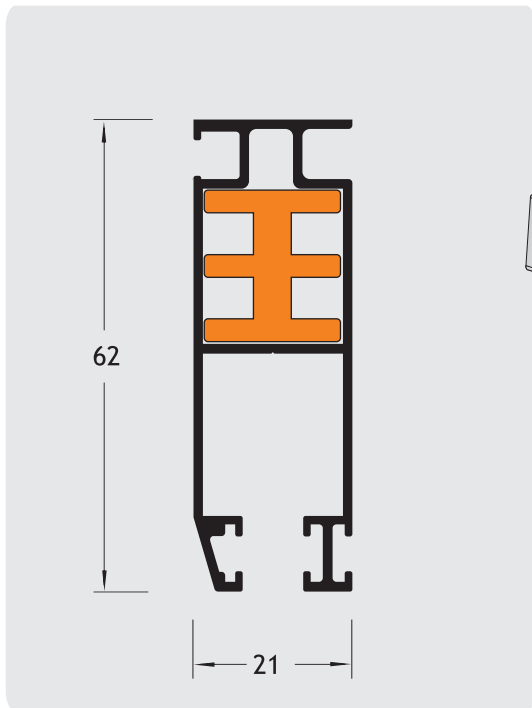

КРИЛО ПРОТИВО-НАСЕКОМНА МРЕЖА FLY-SCREEN SASH	2810
ТЕГЛО / WEIGHT (gr/m)	W=699
Инерционен момент Moments of INERTIA (cm ⁴)	I _x =10,81
	J _y =1,70
Периметър / Perimeter (mm)	P=307
Акcesoари / Accessories	
сглобка / corner	PC01
израв. ъгъл/сглобка alignment corner	

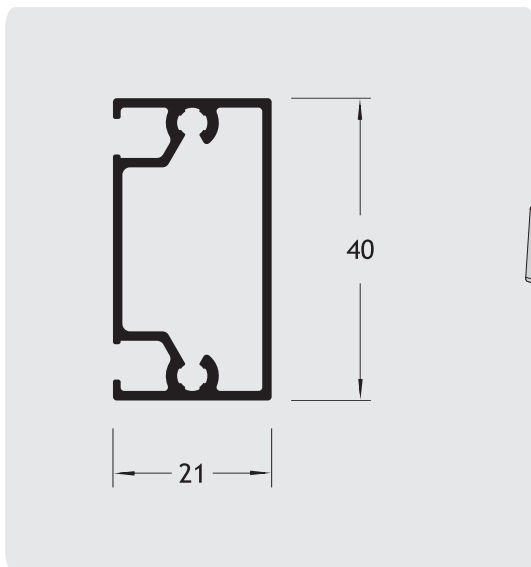

ДЕЛИТЕЛ ПРОТИВО-НАСЕКОМНА МРЕЖА T-PROFILE	2811
ТЕГЛО / WEIGHT (gr/m)	W=509
Инерционен момент Moments of INERTIA (cm ⁴)	I _x =4,01
	J _y =1,07
Периметър / Perimeter (mm)	P=155
Акcesoари / Accessories	
сглобка / corner	
израв. ъгъл/сглобка alignment corner	

ТИПИЧНИ ПЛЪЗГАЩИ РЕШЕНИЯ
TYPICAL SLIDING SOLUTIONS

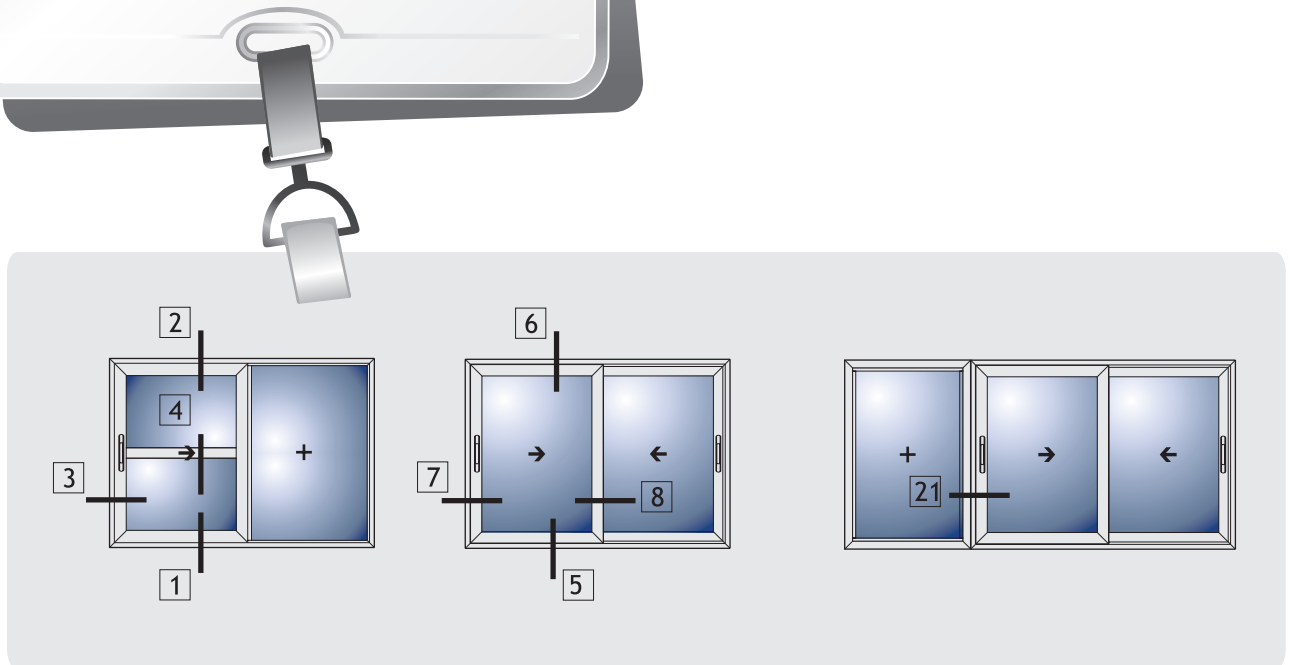

КОМПЛИЦИРАНИ
ПЛЪЗГАЩИ РЕШЕНИЯ
COMPLICATED SLIDING SOLUTIONS

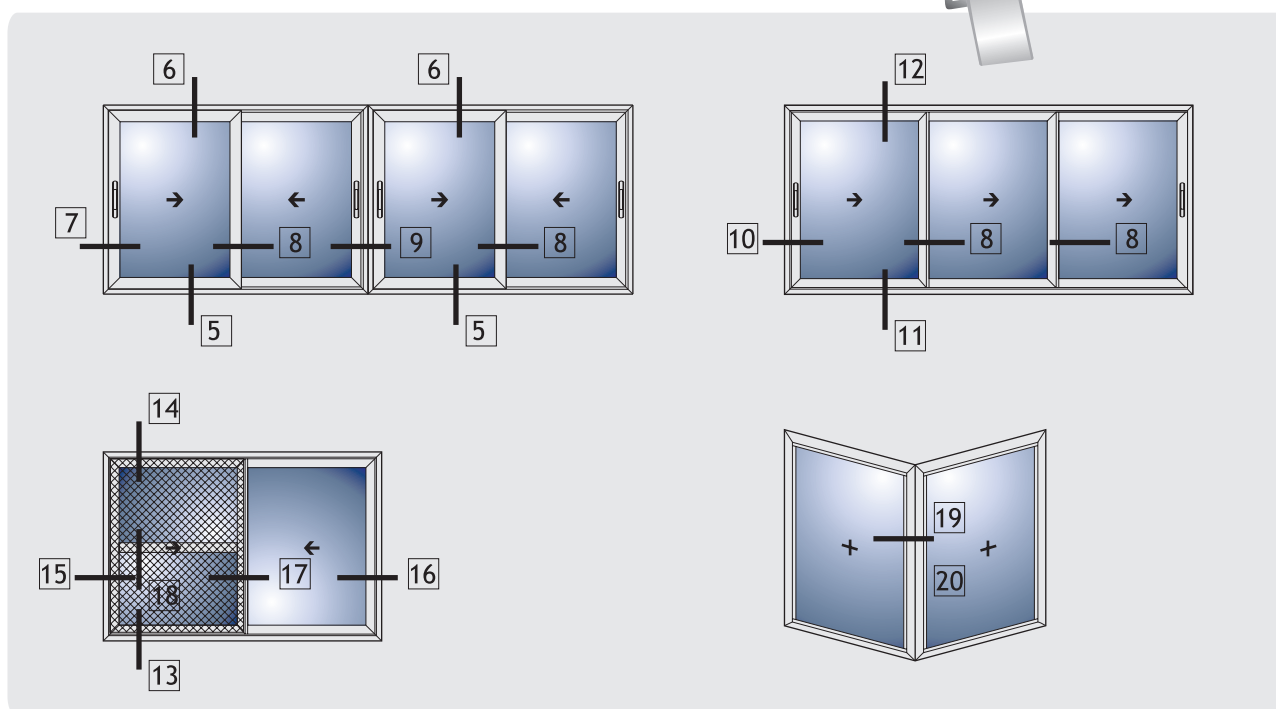

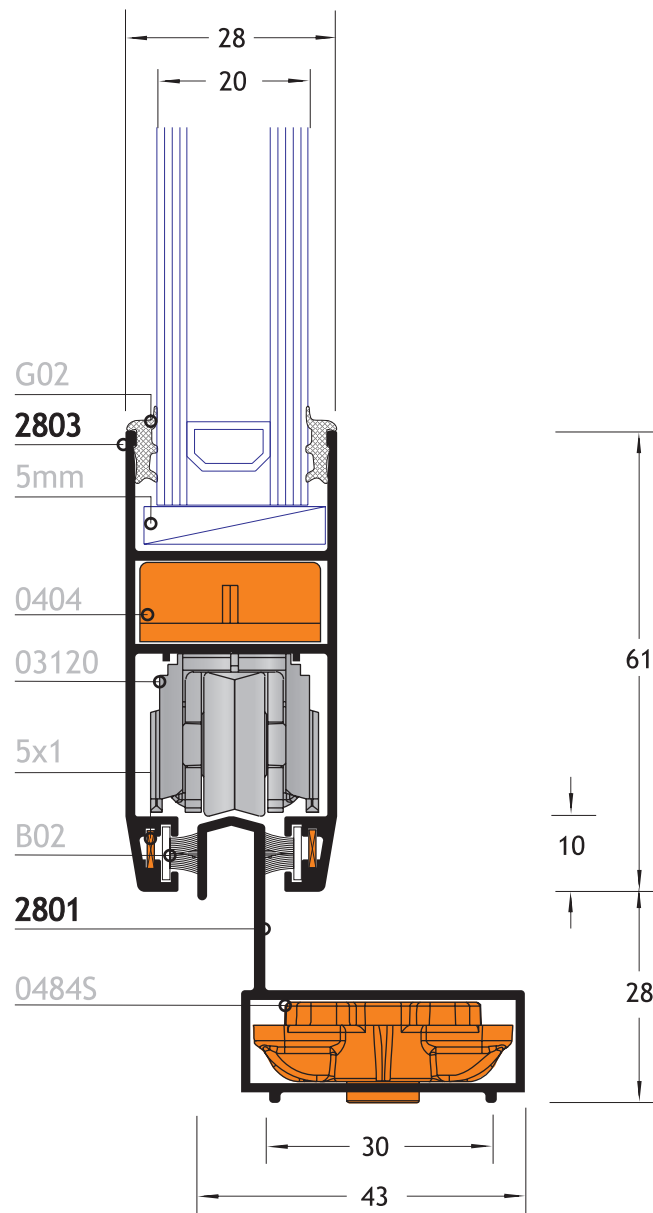
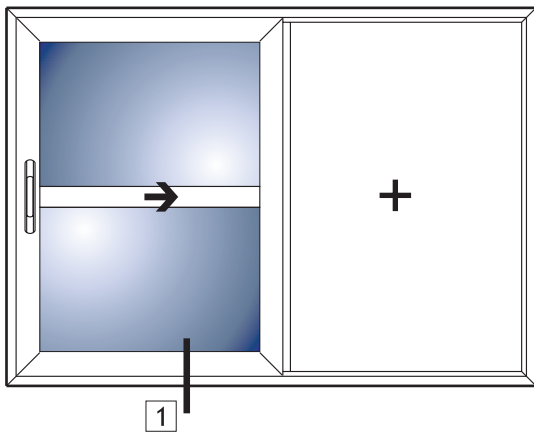

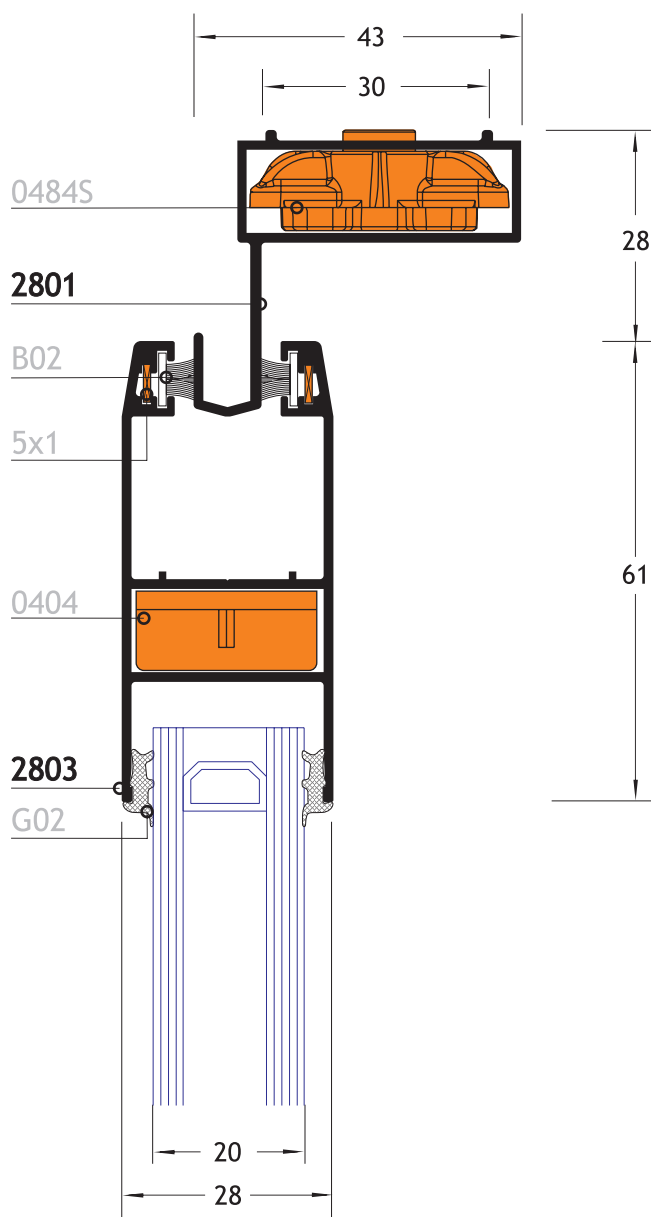
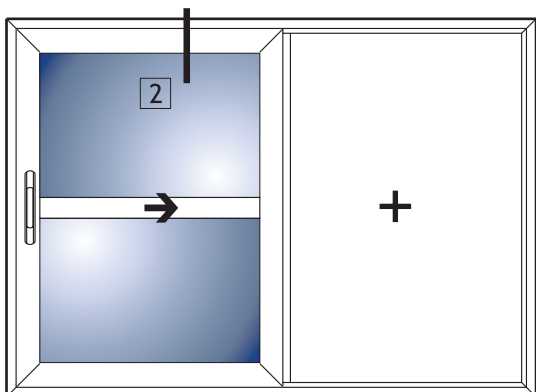

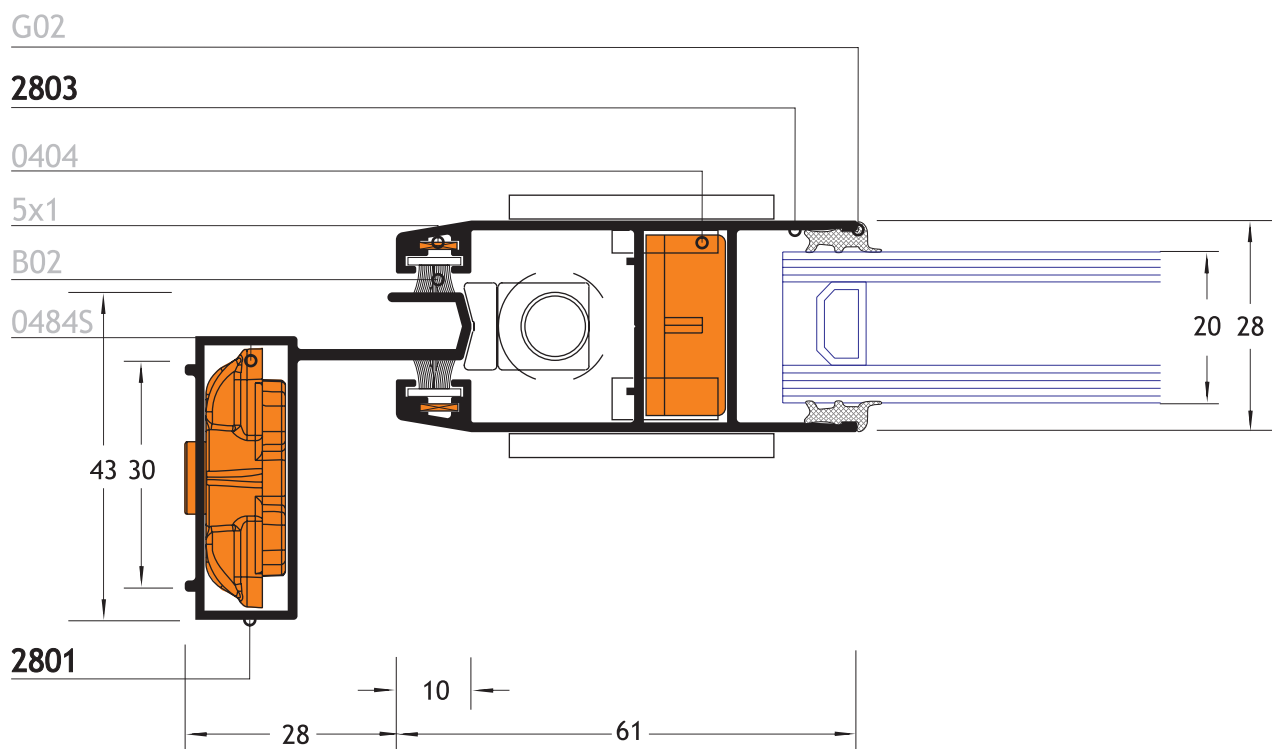
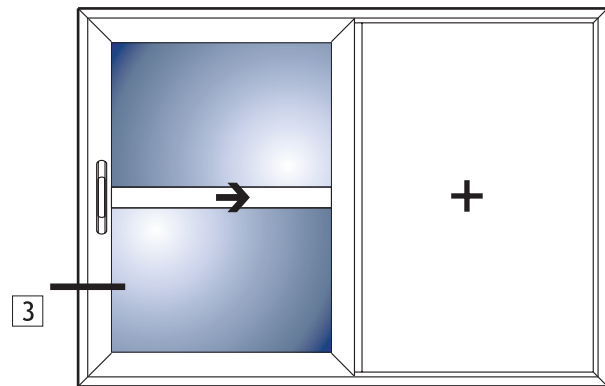

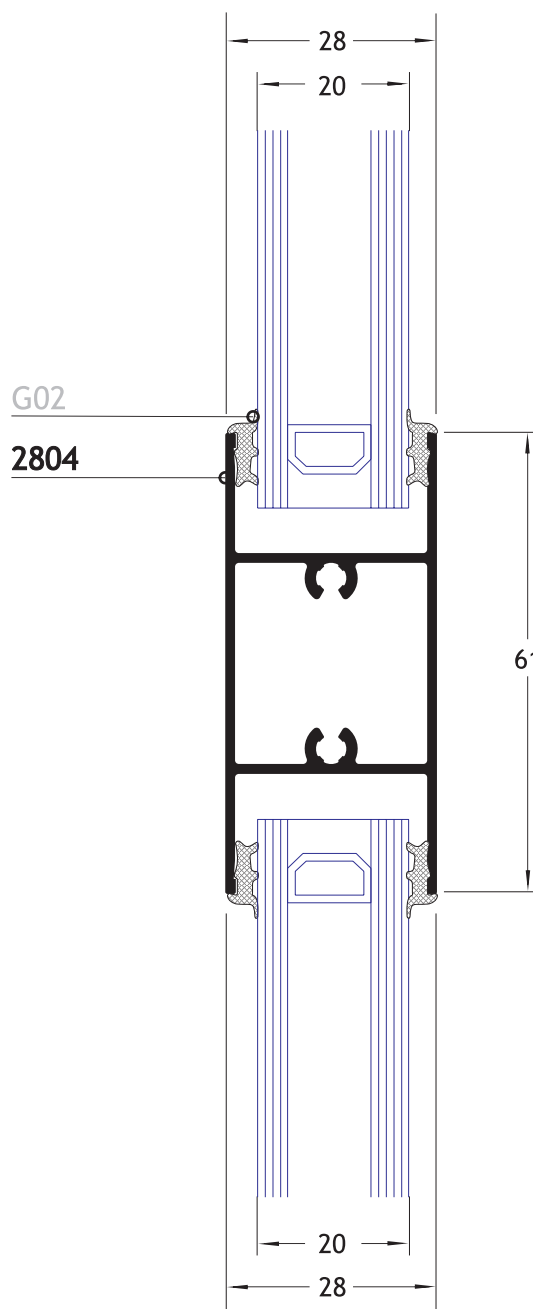
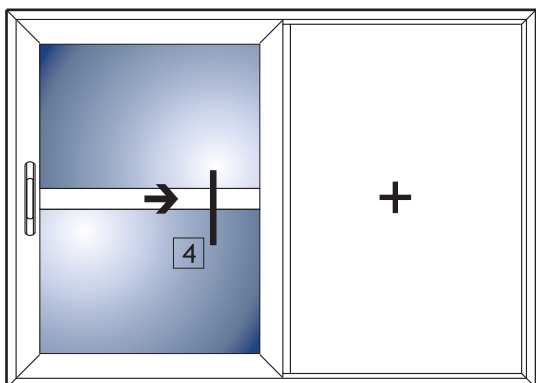

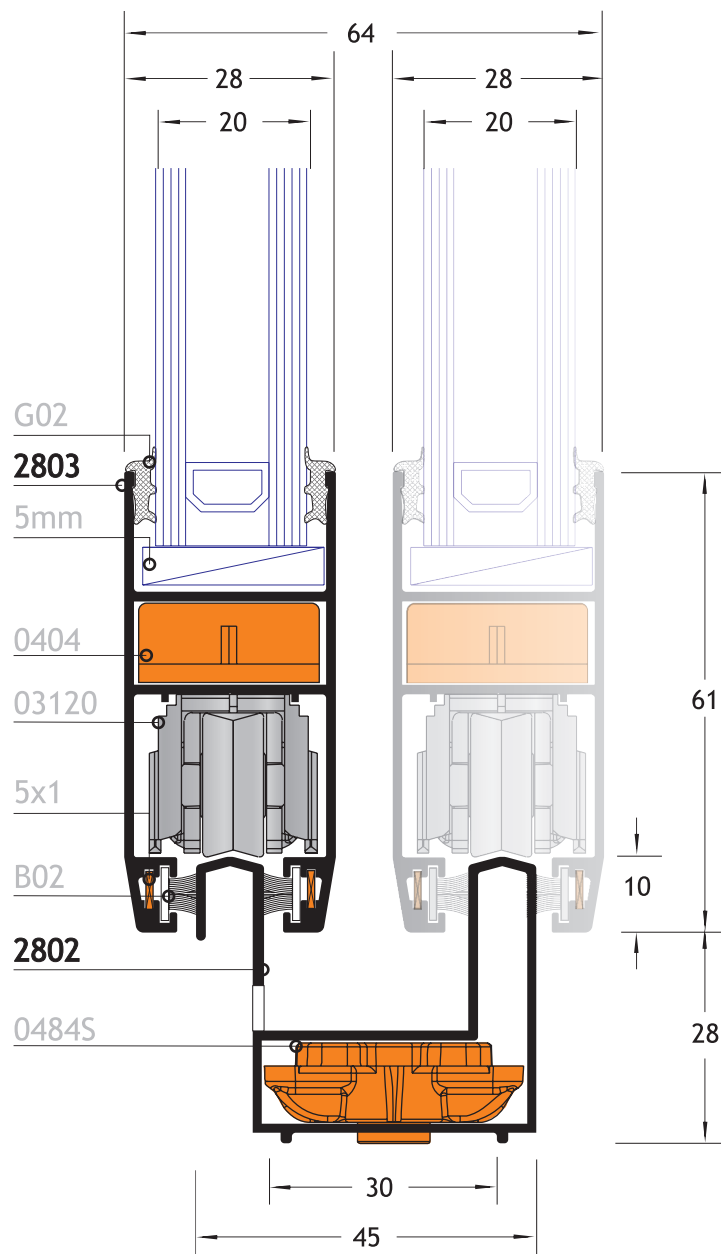
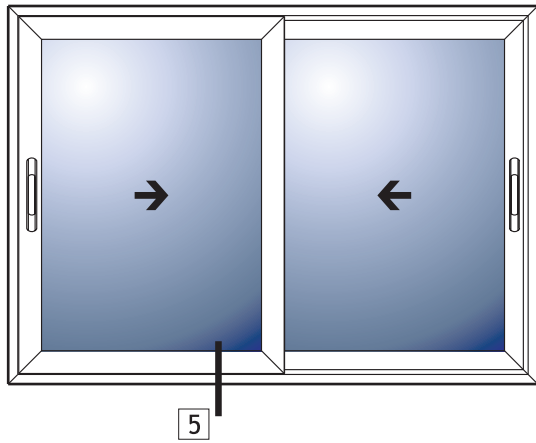

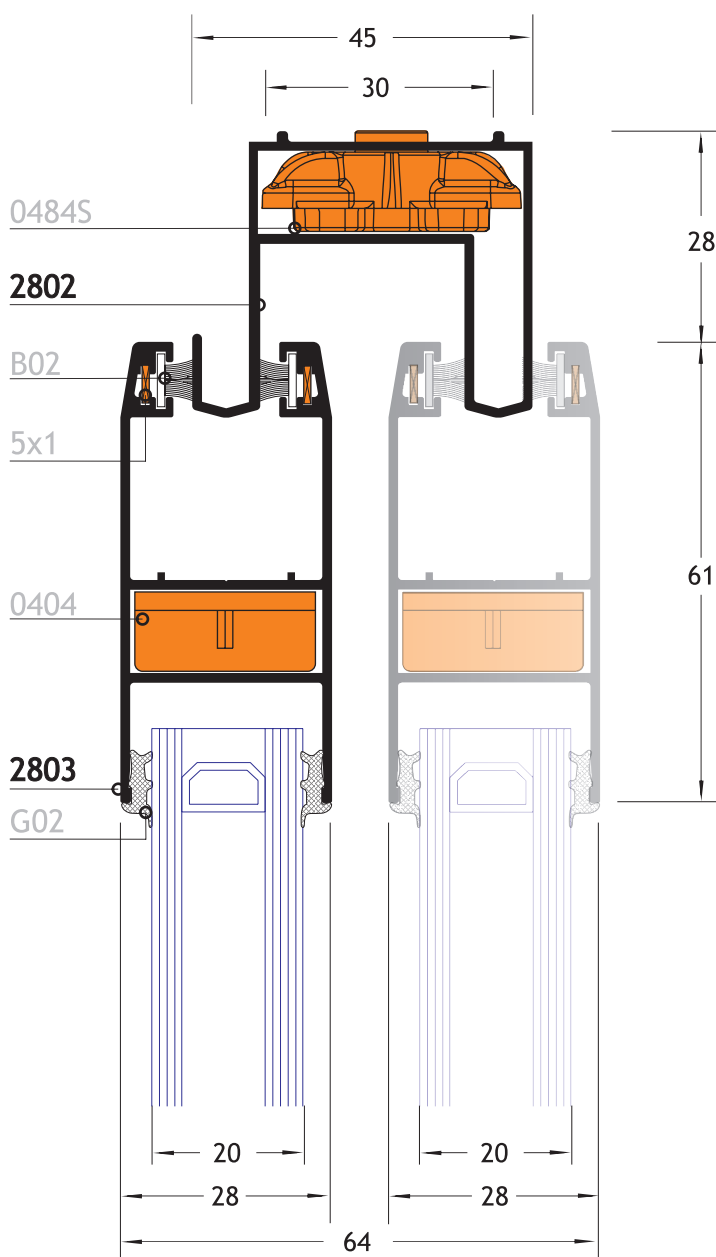
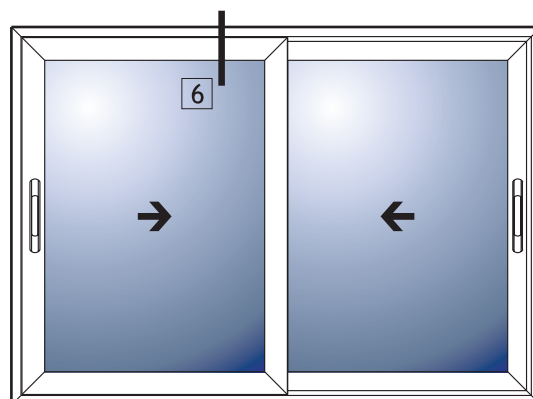

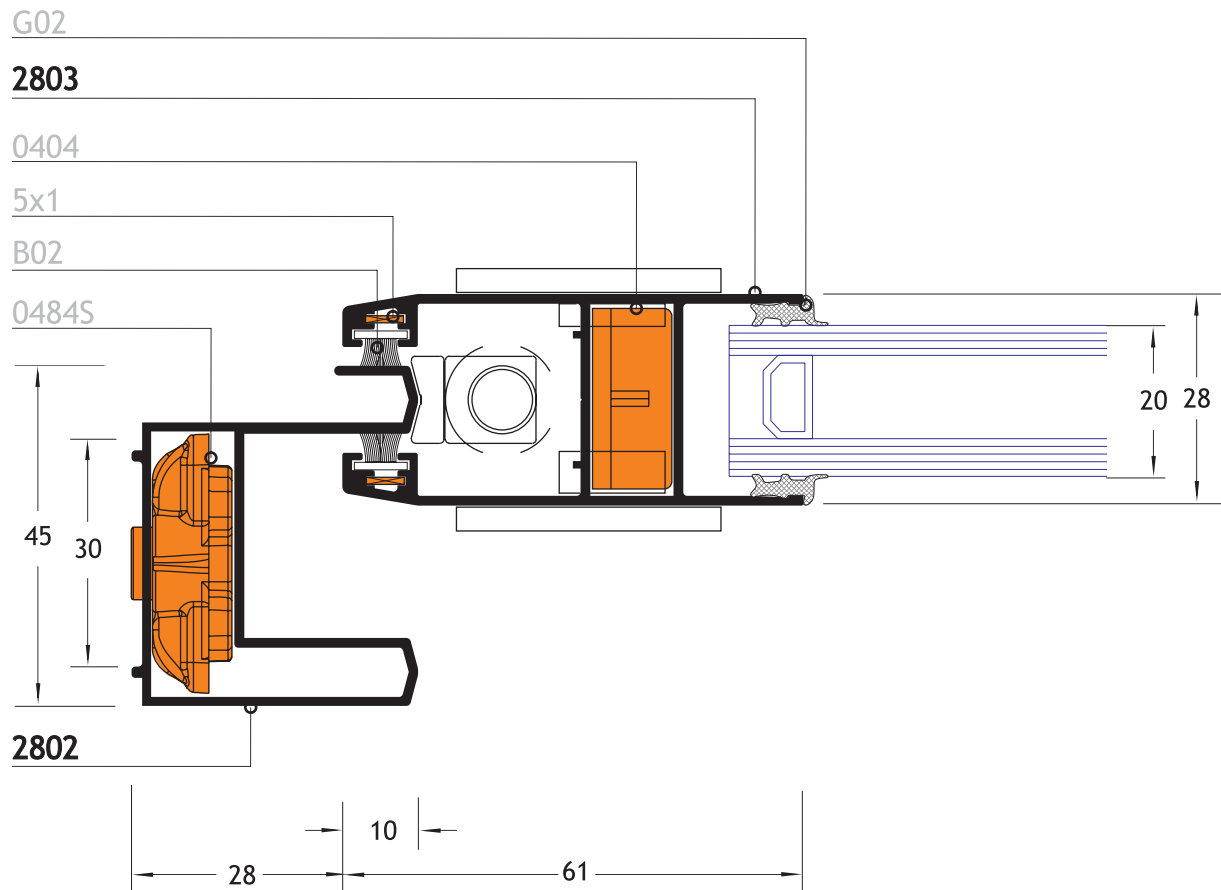
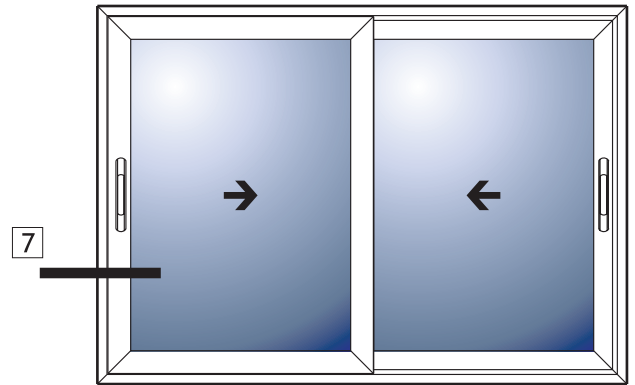

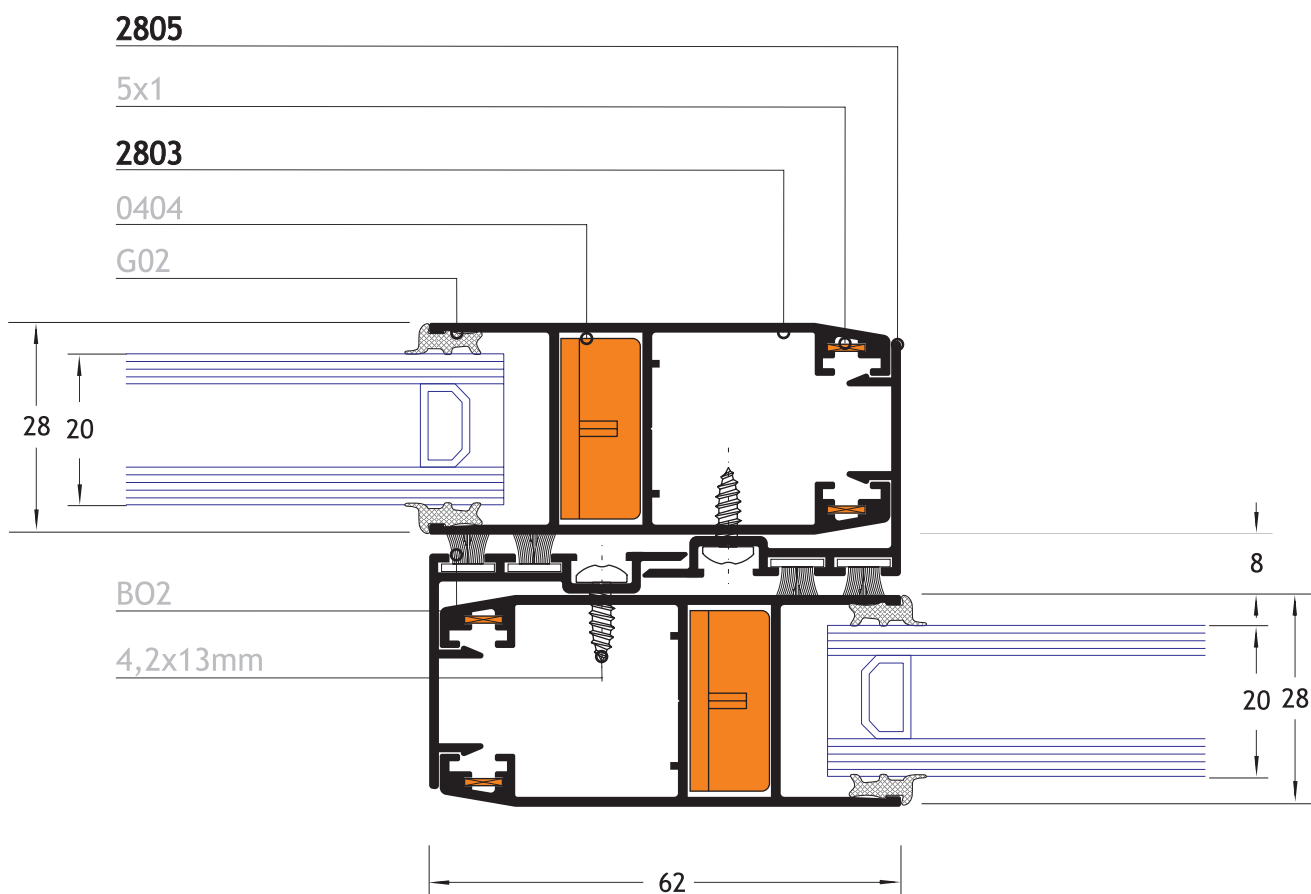
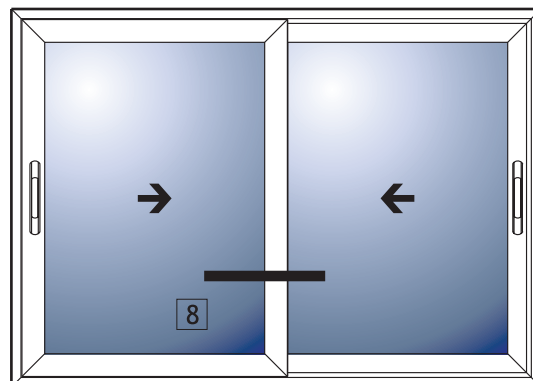

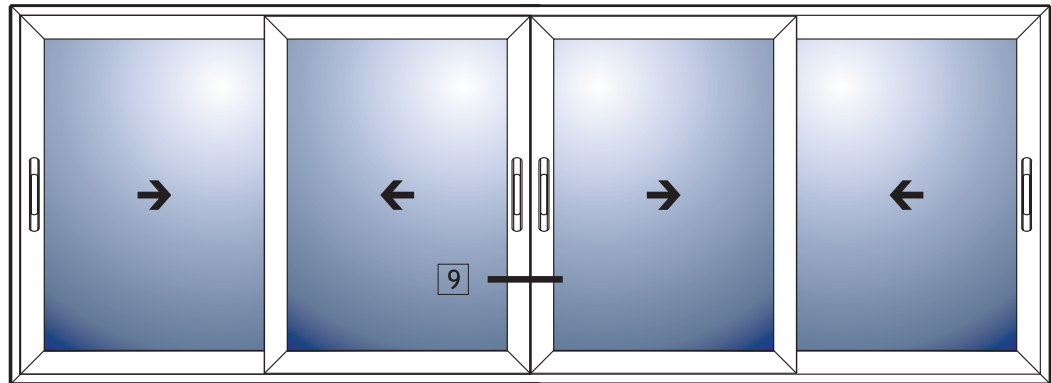

G02

2803

0404

5x1

2806

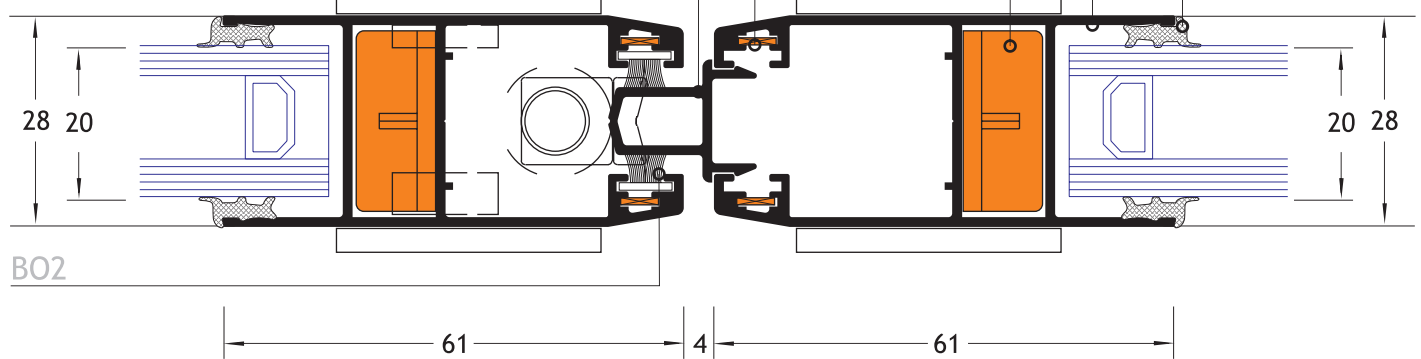

B02

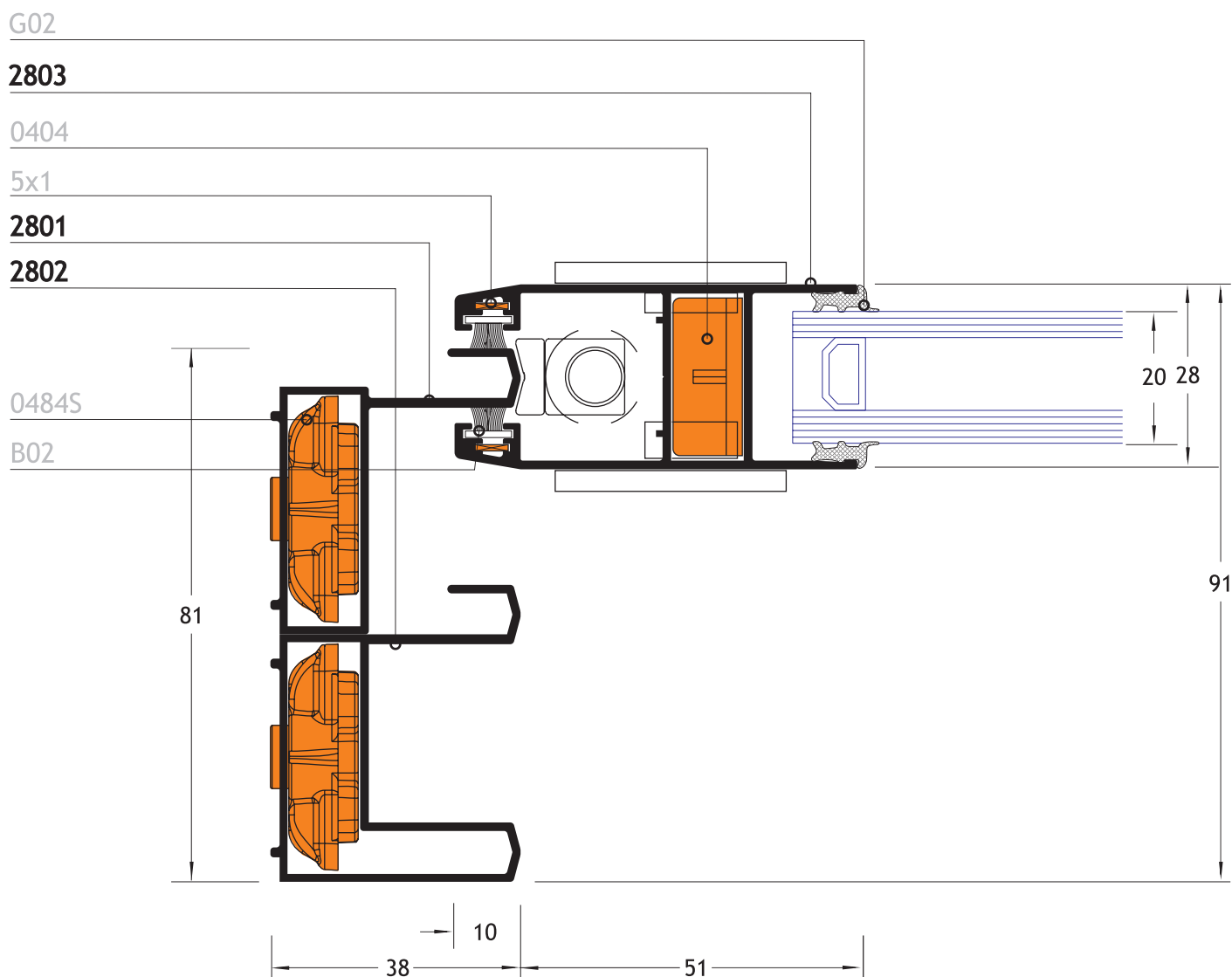
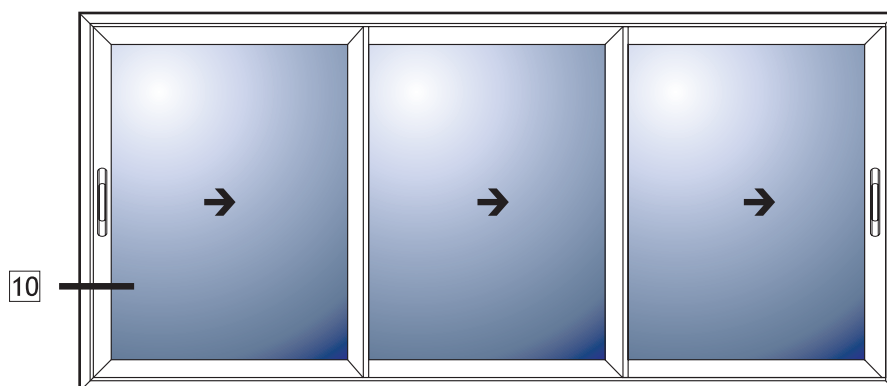

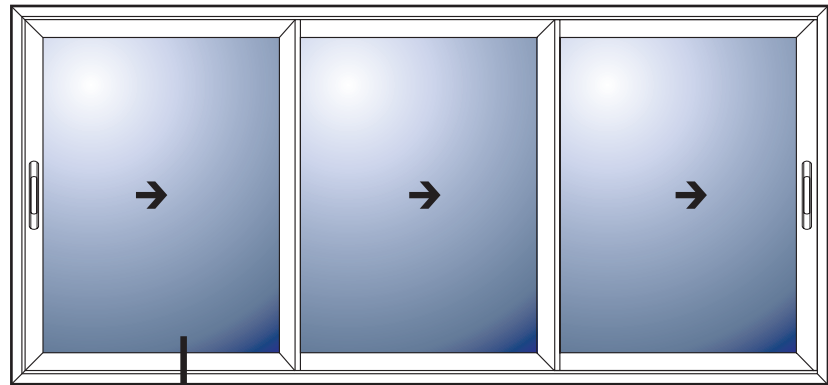

11

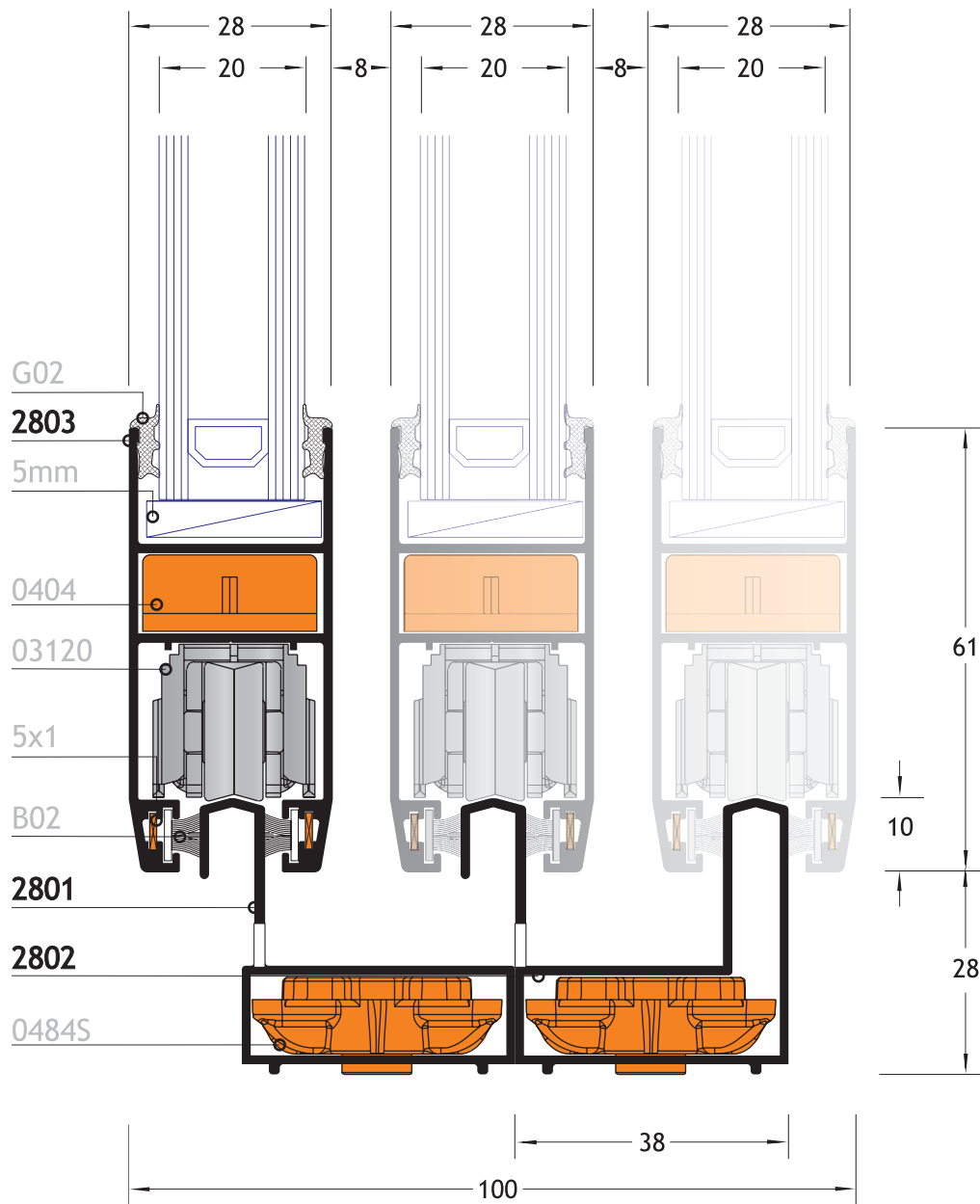

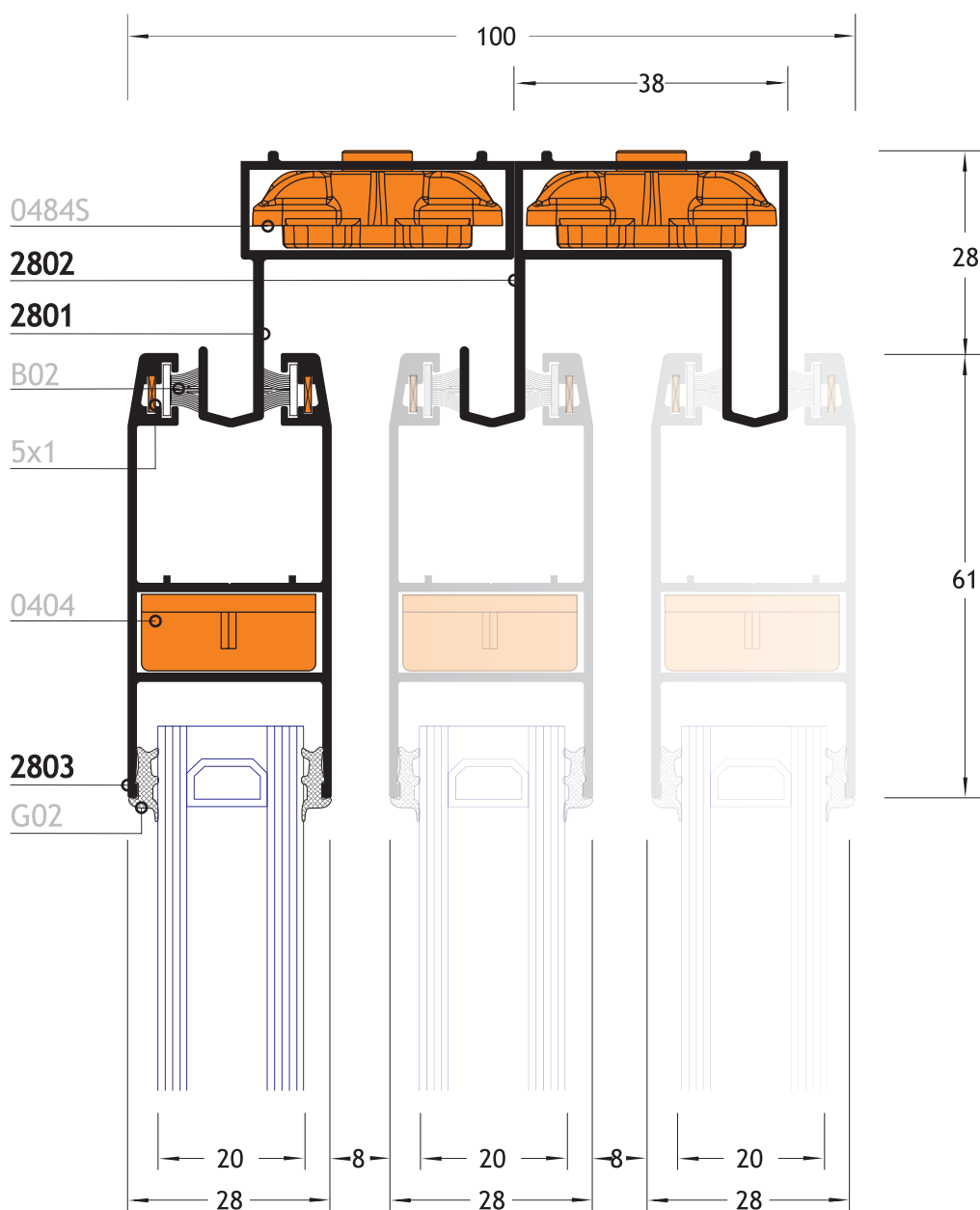
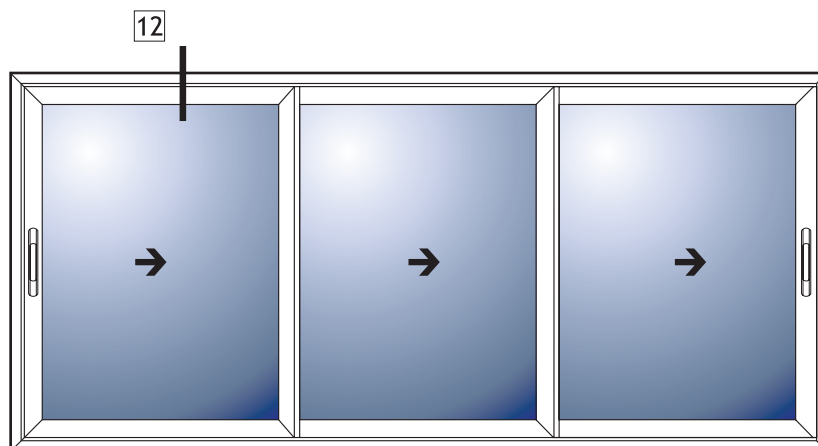

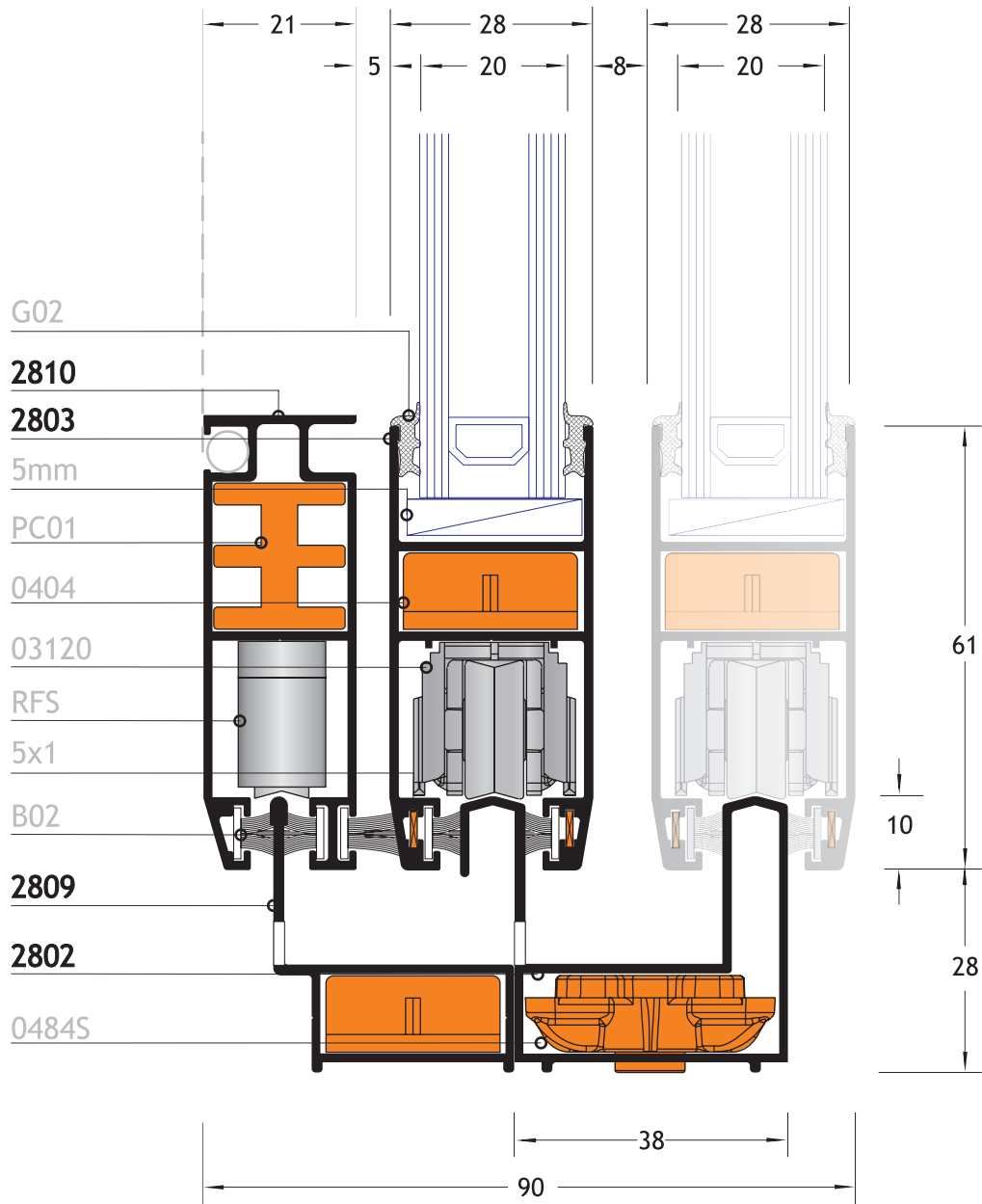
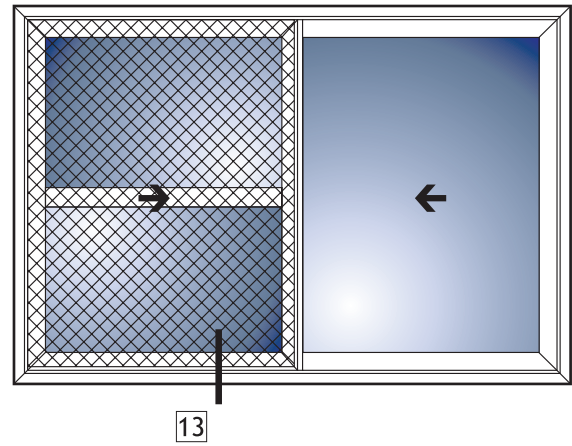

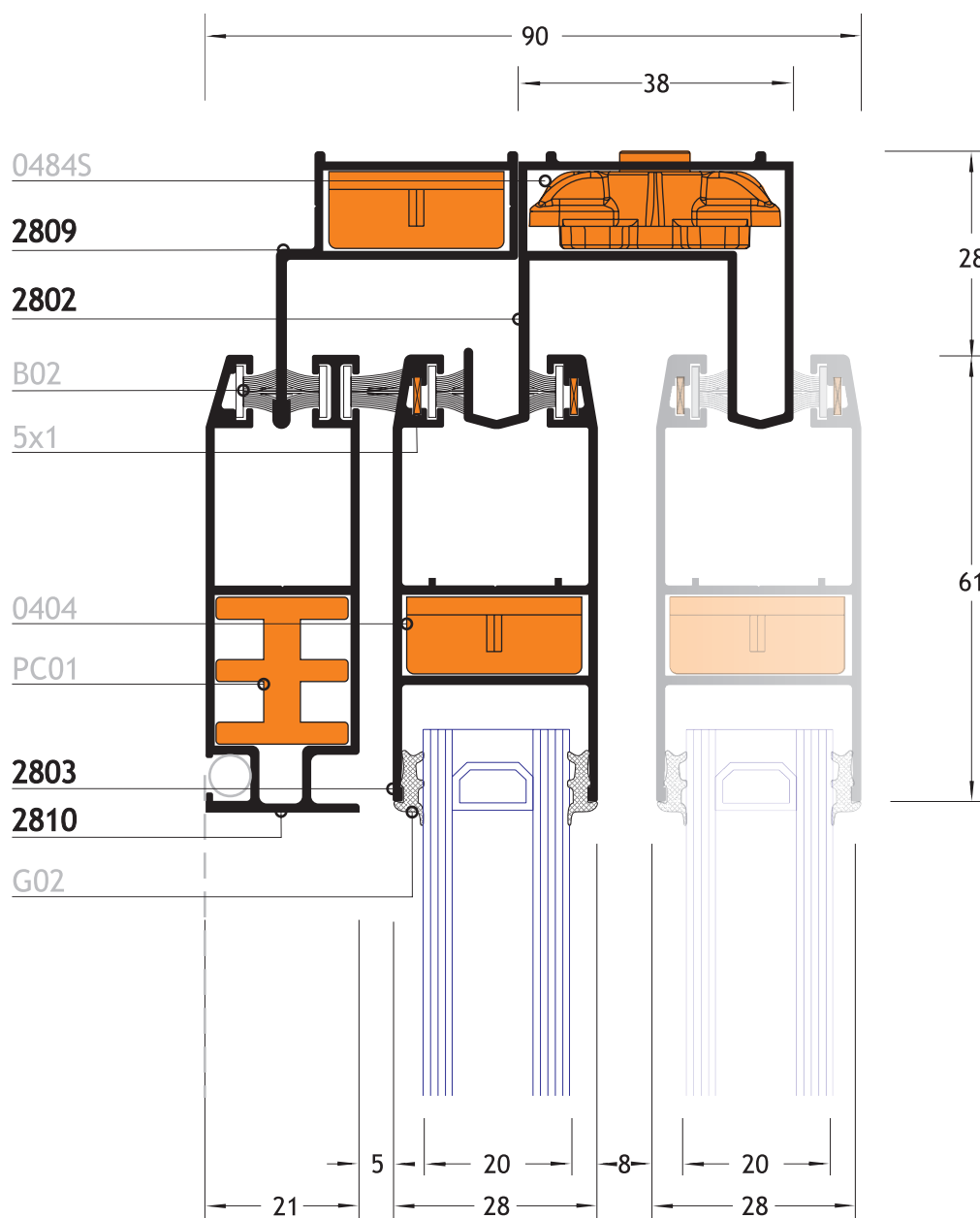
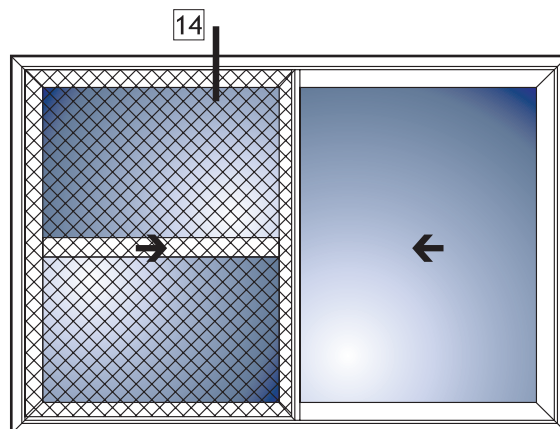

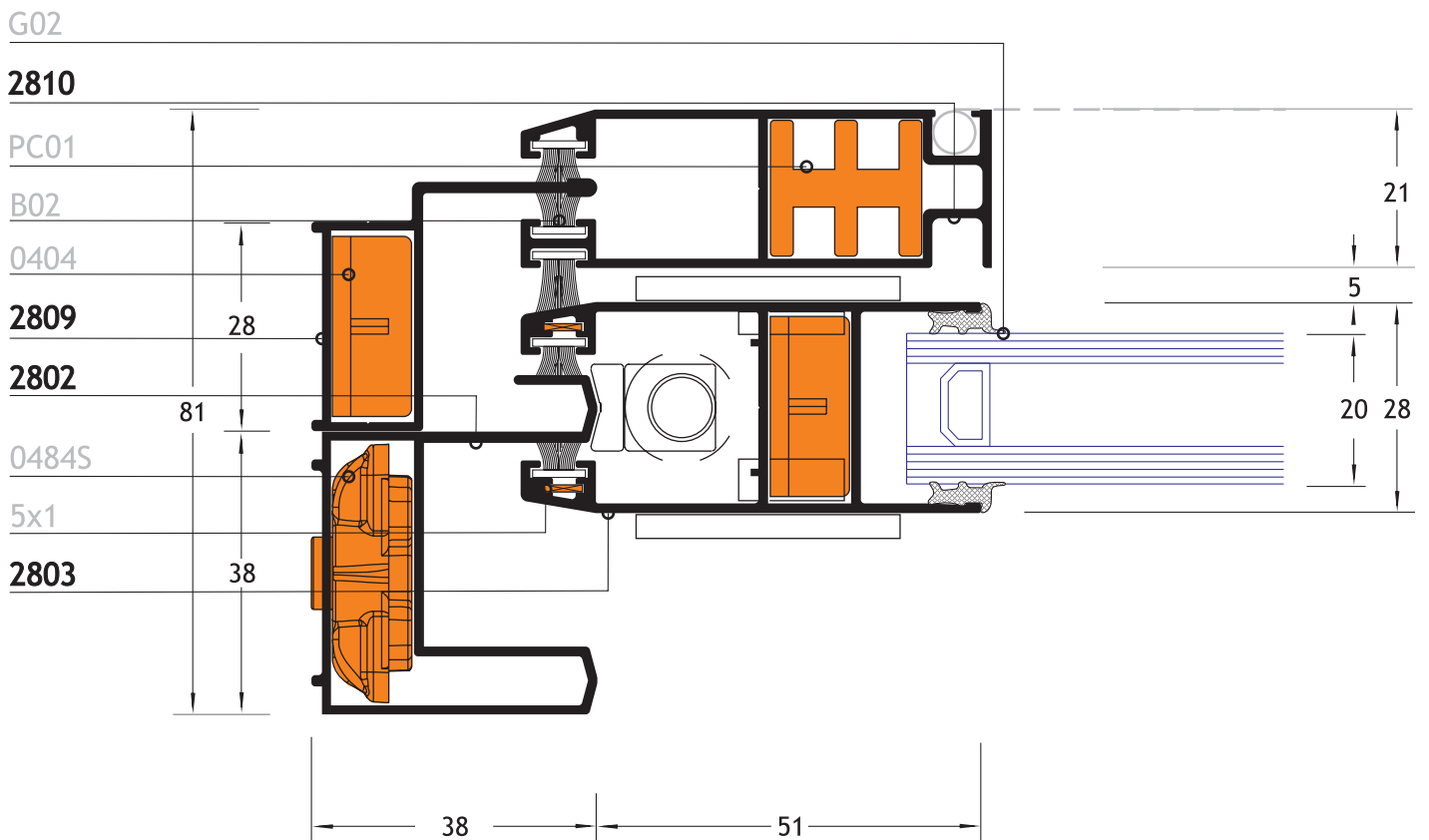
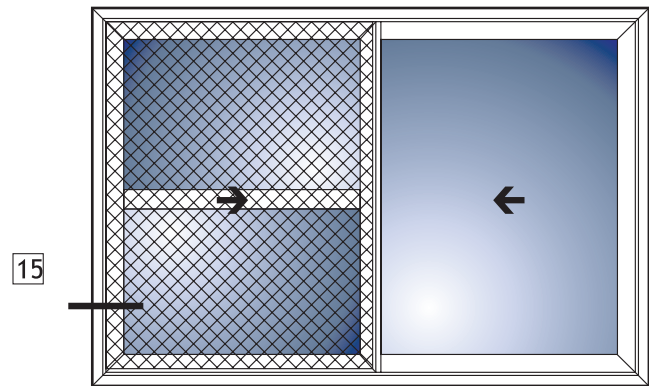

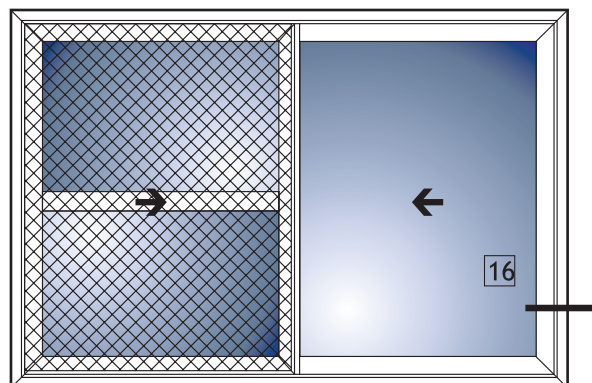

2809

0404

2802

5x1

2803

G02

B02

0484S

28 20

28

81

38

51

38

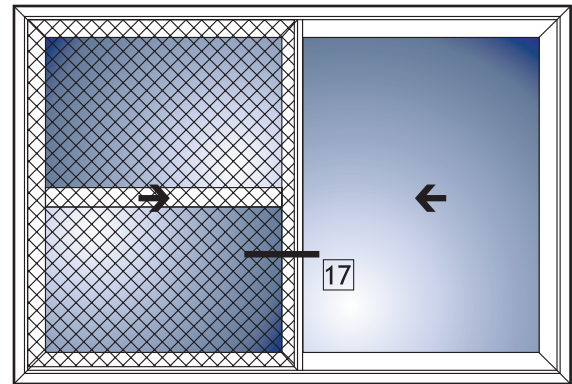

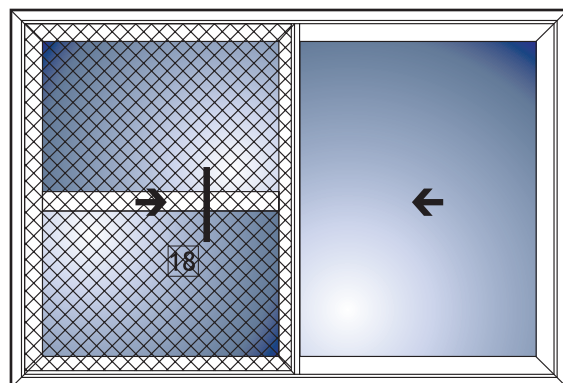
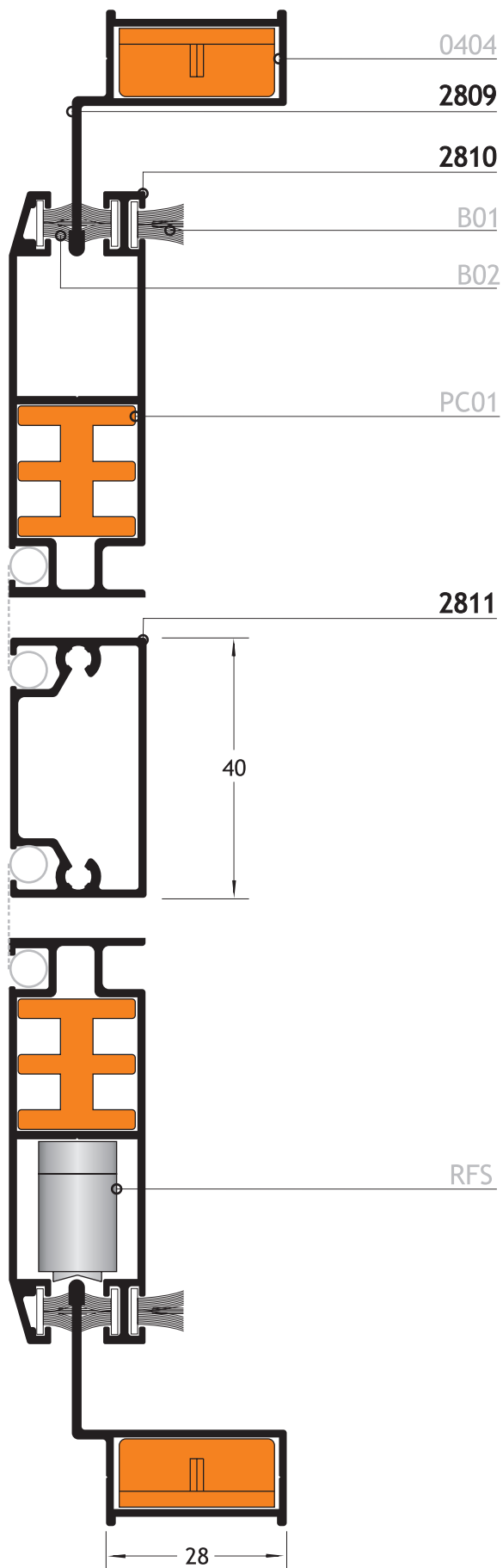

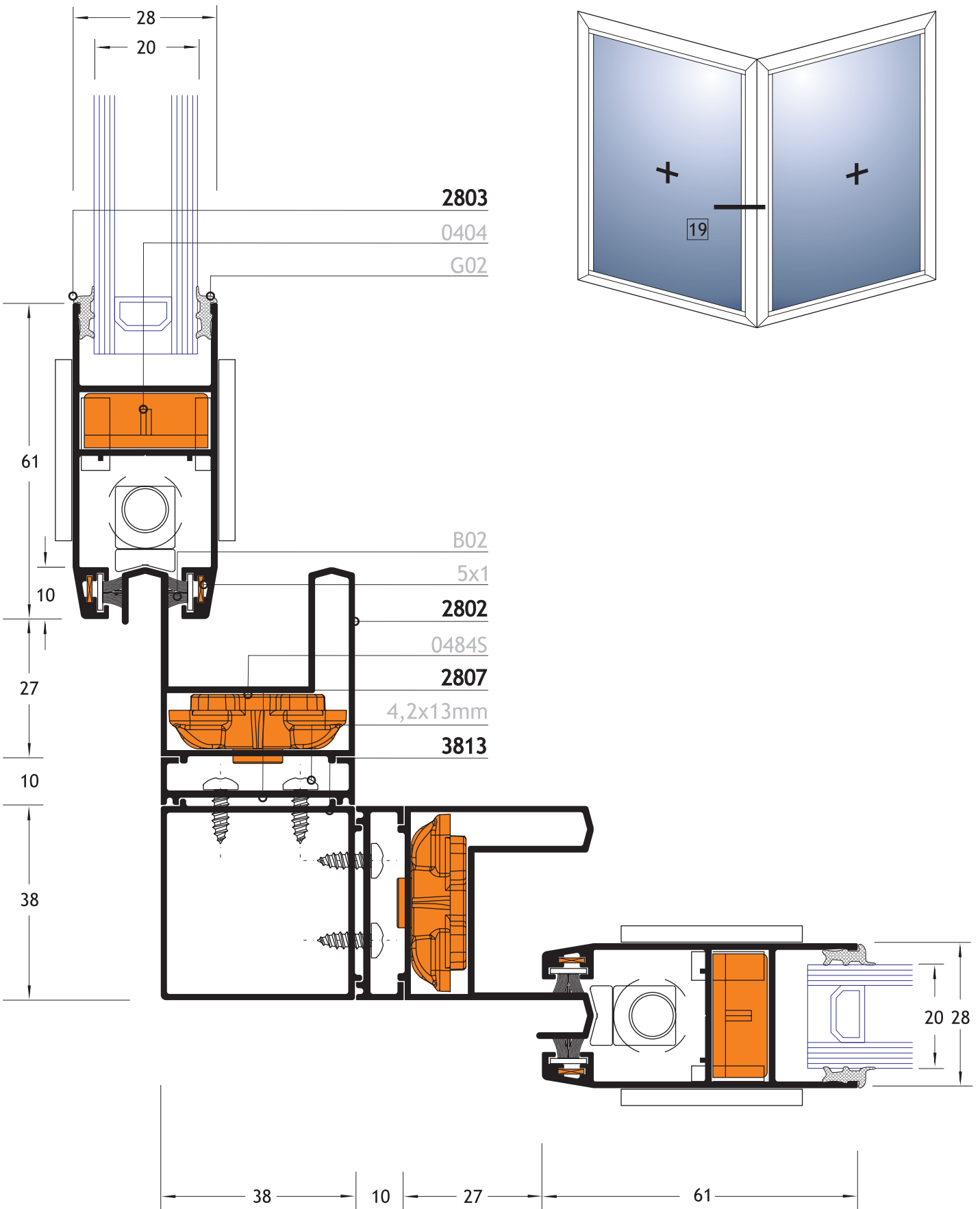

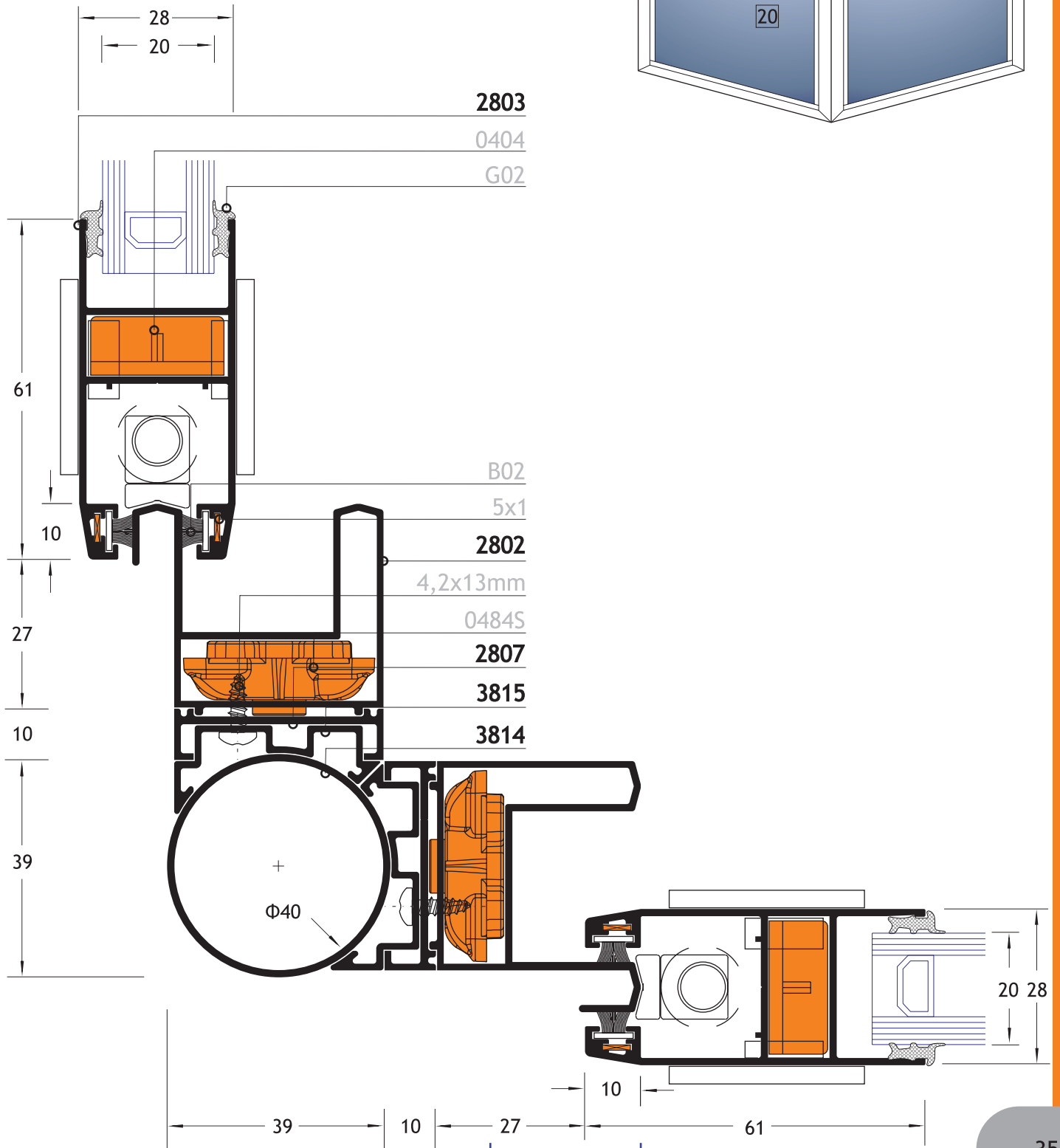
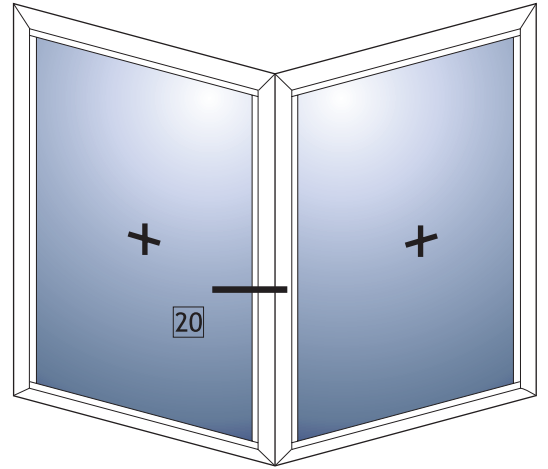

СЕЧЕНИЯ 1:1 | SECTION 1:1 | 2019

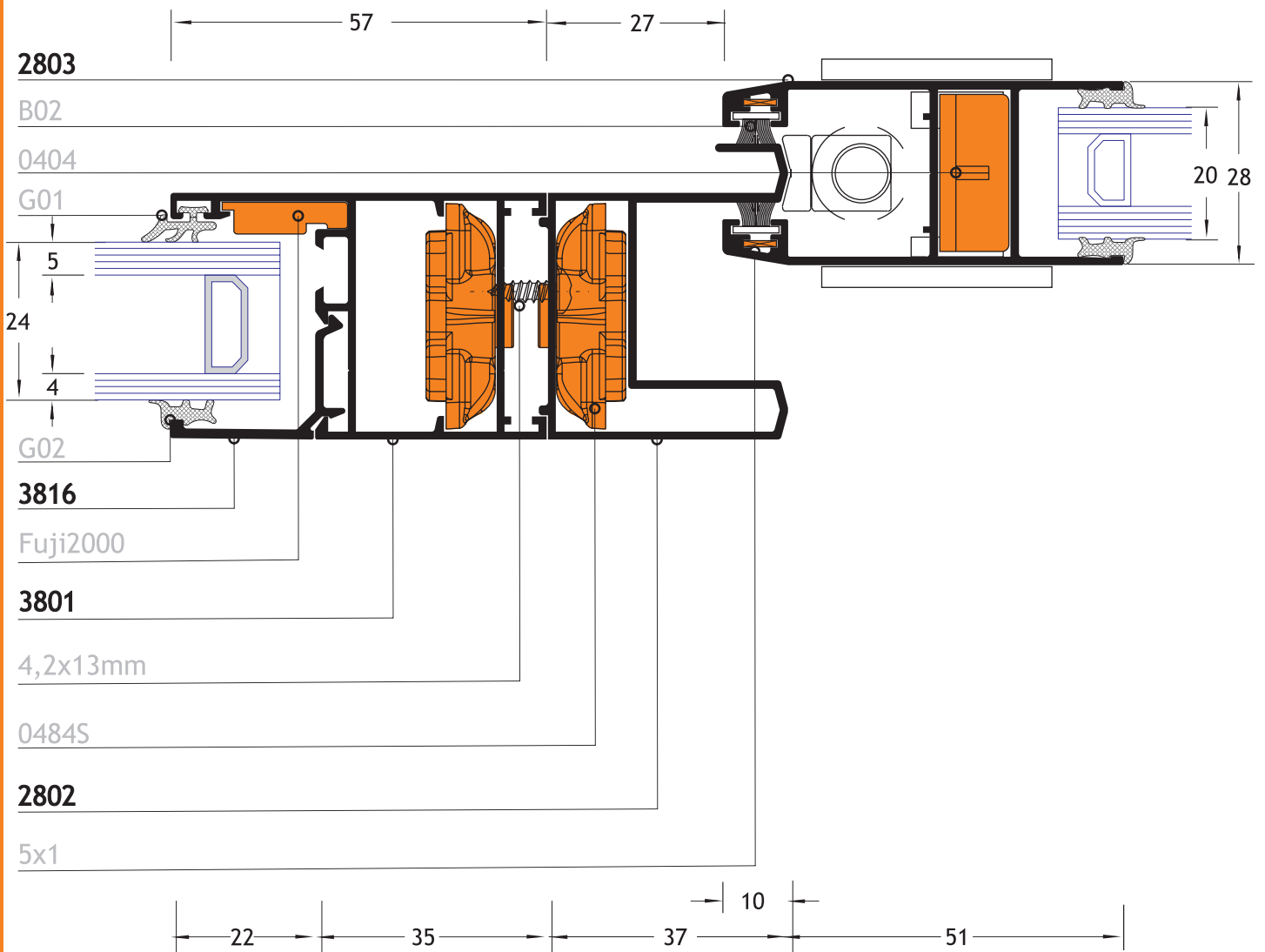
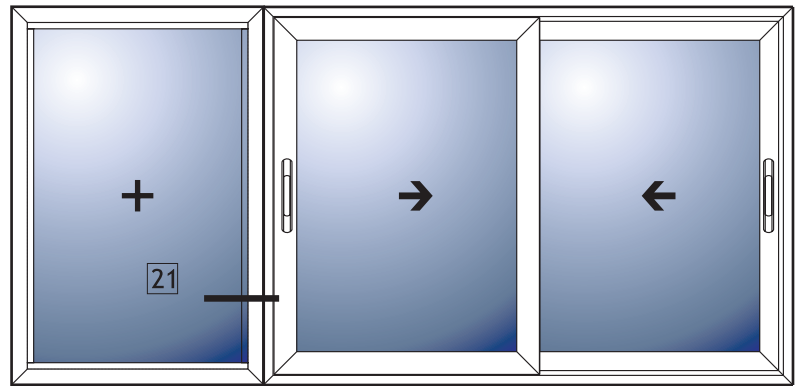

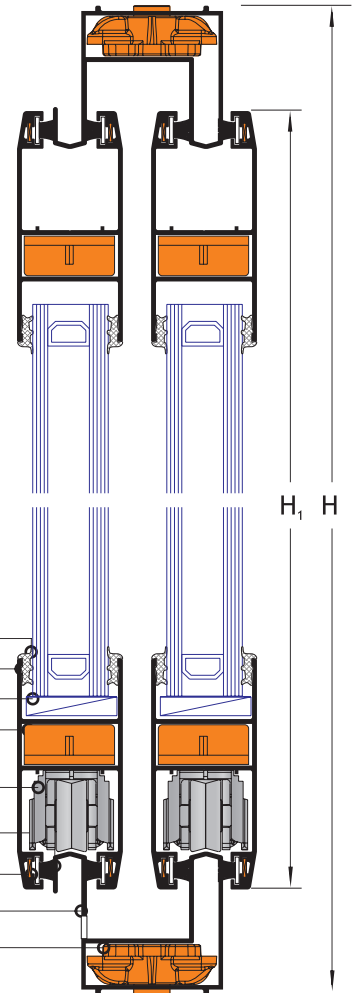
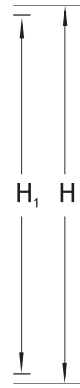
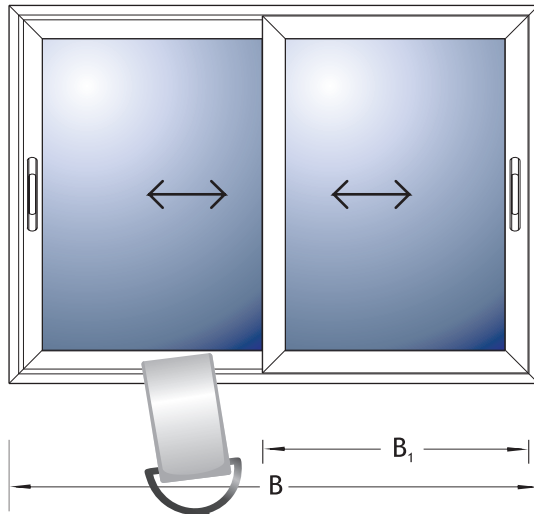

- G02
- 2803**
- 5mm
- 0404
- 03120
- B02
- 5x1
- 2802**
- 0484S

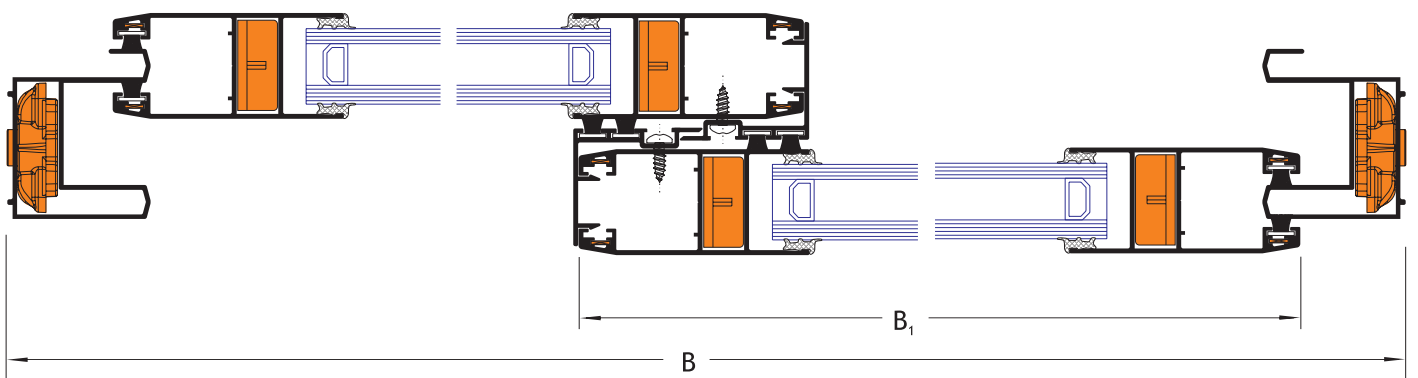
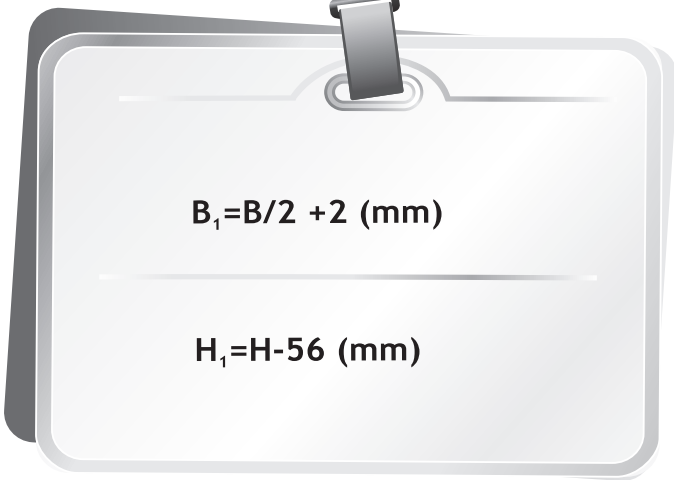

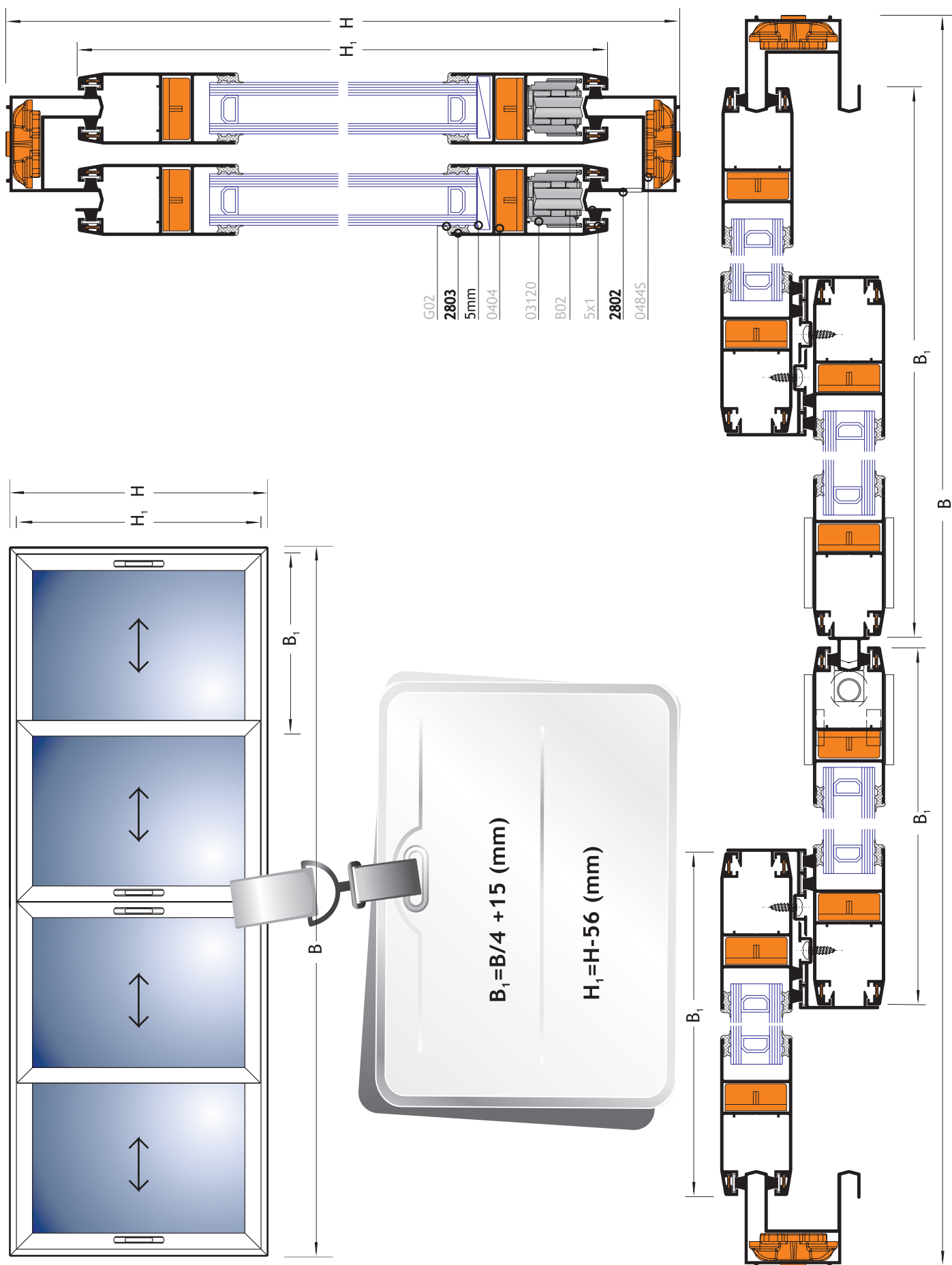

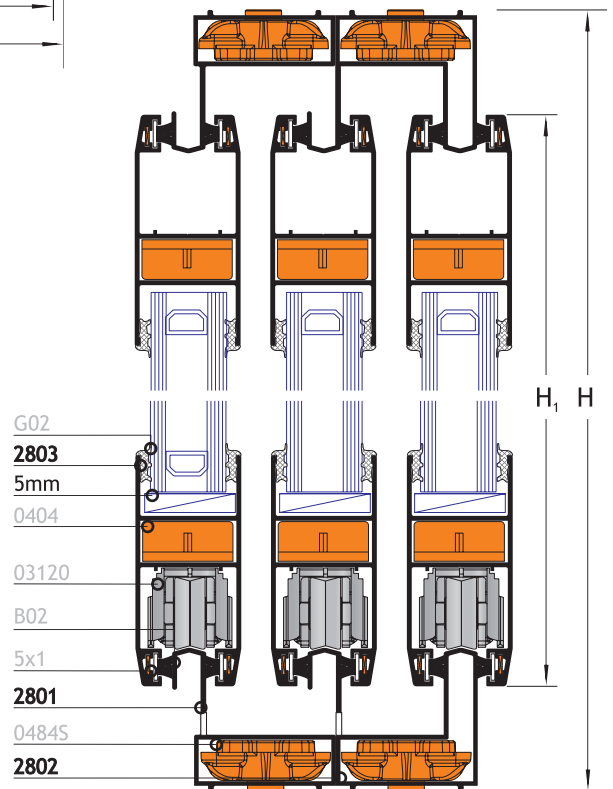
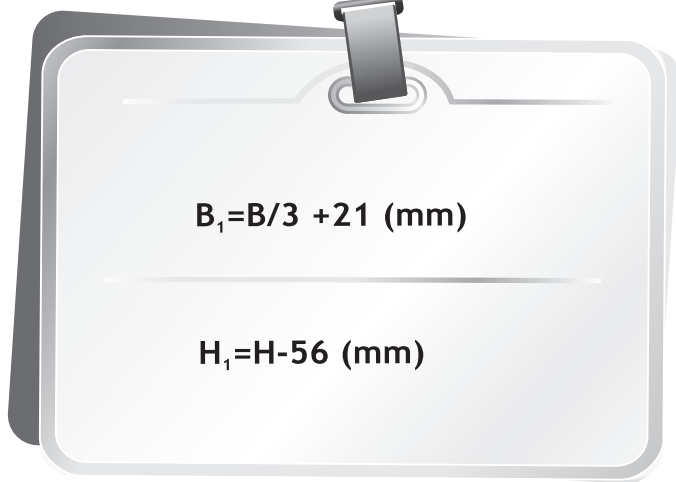
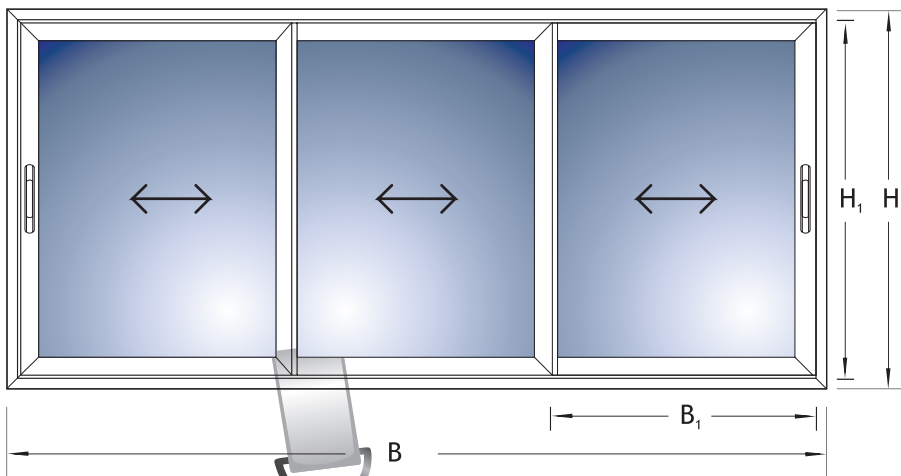



AKCECOAPI

ACCESSORIES

СГЛОБКИ / CORNERS

ВИНТОВИ СГЛОБКИ
SCREW CONNECTING CORNERS

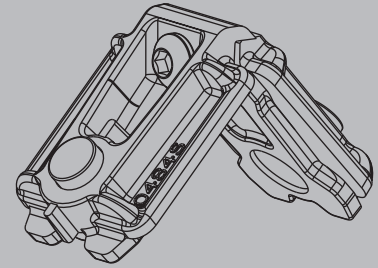
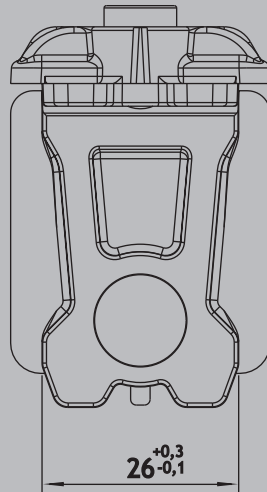
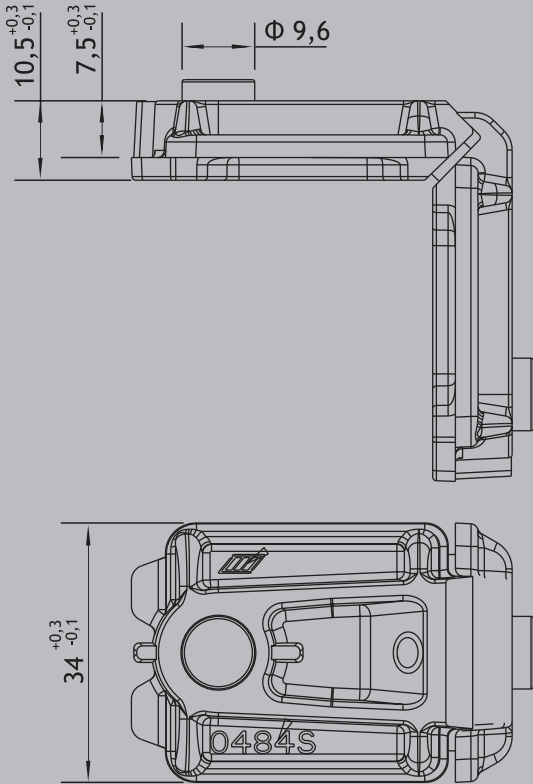

ВИНТОВА СГЛОБКА | 0484S
SCREW CONNECTING CORNER

МАТЕРИАЛ | Лят алуминий
MATERIAL | Die cast aluminium

ЦВЯТ |
COLOR | Mill finish

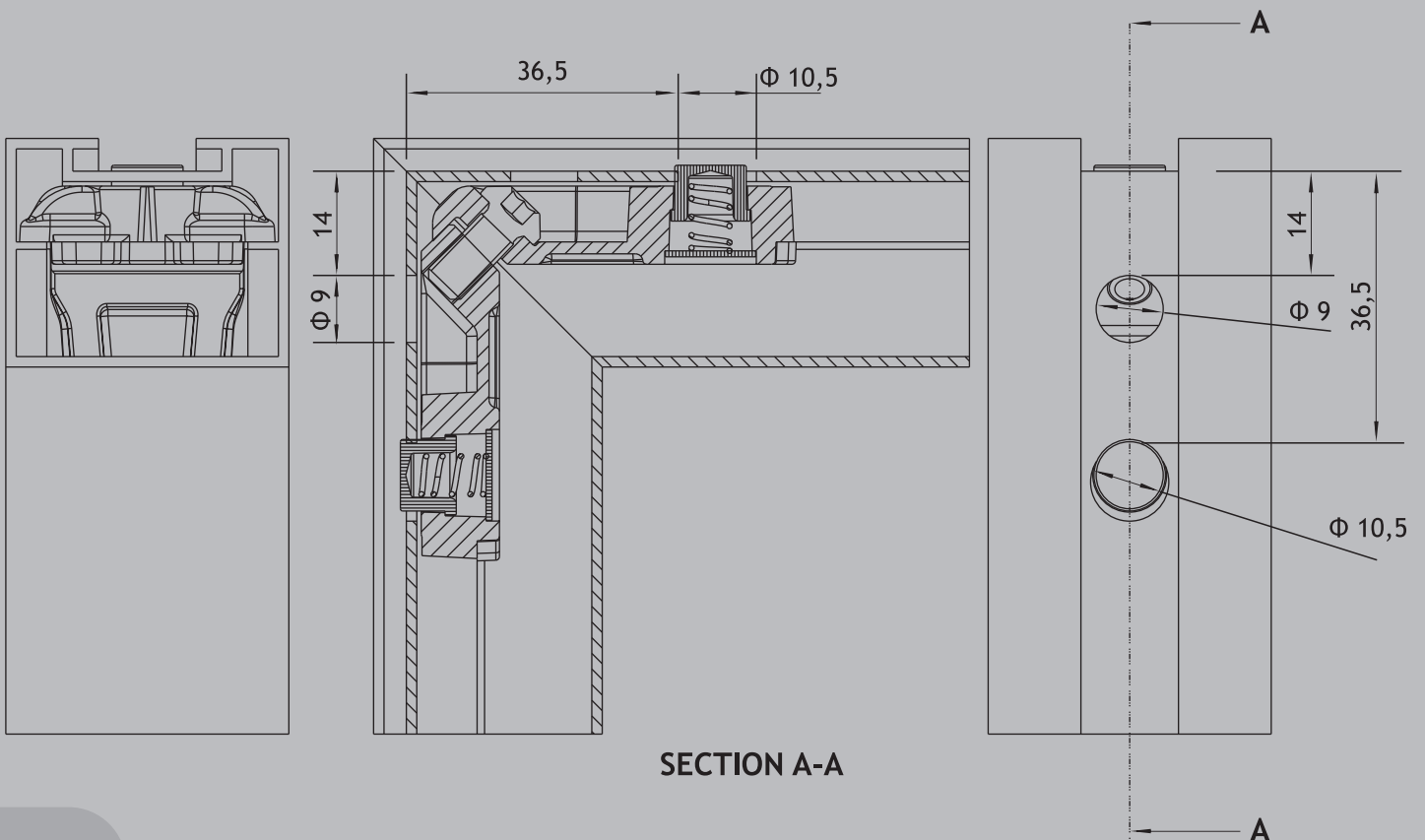

SECTION A-A

СГЛОБКИ / CORNERS

ВИНТОВИ СГЛОБКИ
SCREW CONNECTING CORNERS

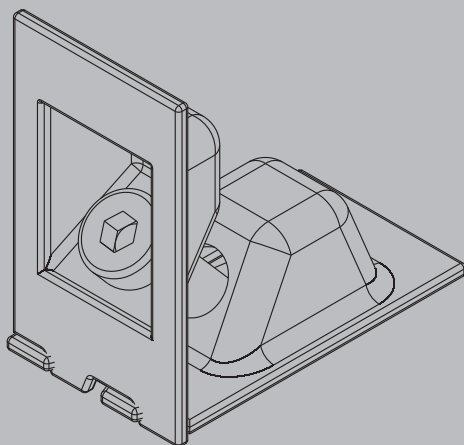

ВИНТОВА СГЛОБКА | 3054
SCREW CONNECTING CORNER

МАТЕРИАЛ | Метал
MATERIAL | Metal

ЦВЯТ | Mill finish
COLOR | Mill finish

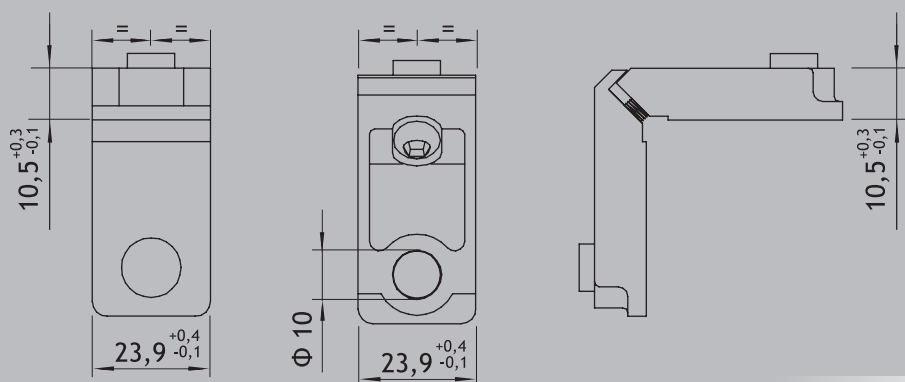

ВИНТОВА СГЛОБКА | 0404
SCREW CONNECTING CORNER

МАТЕРИАЛ | Лят алуминий
MATERIAL | Die cast aluminium

ЦВЯТ | Mill finish
COLOR | Mill finish

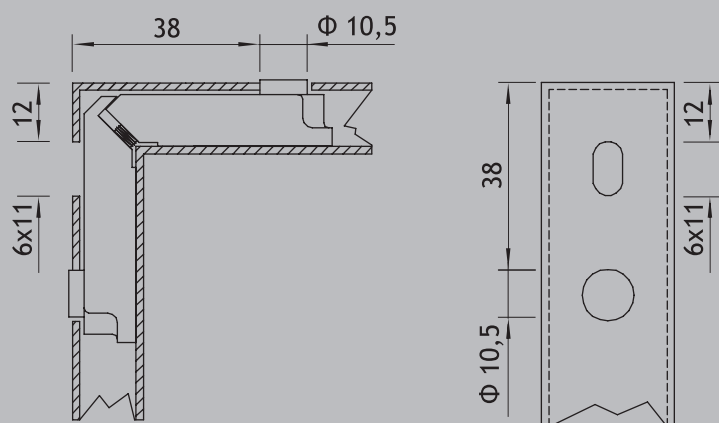

СГЛОБКИ / CORNERS

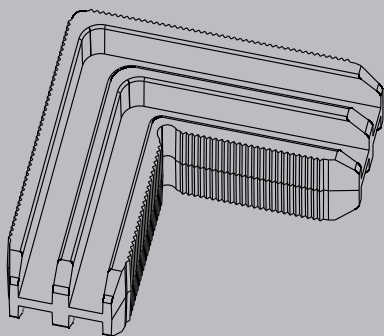

ИЗРАВНИТЕЛНИ ЪГЛИ
ADJOINING CORNERS

ИЗРАВНИТЕЛЕН ЪГЪЛ
ADJOINING CORNER

Pc01

МАТЕРИАЛ | Пластмаса
MATERIAL | Plastic

ЦВЯТ |
COLOR | Mill finish

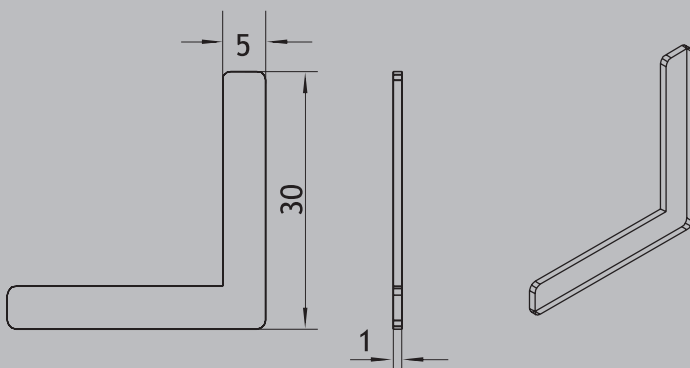

ИЗРАВНИТЕЛЕН ЪГЪЛ
ADJOINING CORNER

5x1

МАТЕРИАЛ | Метал
MATERIAL | Metal

ЦВЯТ |
COLOR | Mill finish

УПЛЪТНИТЕЛИ / GASKETS



УПЛЪТНИТЕЛ
GLAZING GASKET

G02

МАТЕРИАЛ | EPDM
MATERIAL | EPDM

ЦВЯТ | Черен
COLOR | Black

ЧЕТКИ / BRUSHES

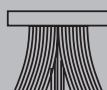

ЧЕТКА 6 мм
BRUSH 6mm

B02

АКСЕСОАРИ КЪМ ПЛЪЗГАЩА СИСТЕМА S28 / ACCESSORIES FOR SLIDING SYSTEM S28

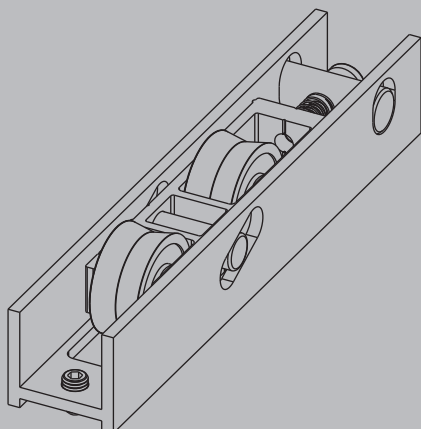

ДВОЙНА РОЛКА | 3017
DOUBLE WHEEL

МАТЕРИАЛ | Метал
MATERIAL | Metal

ЦВЯТ |
COLOR | Mill finish

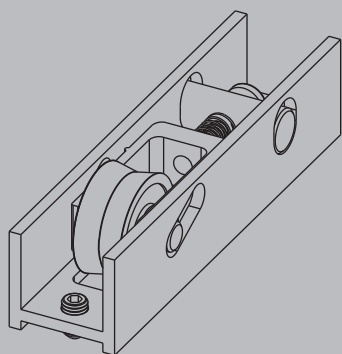

ЕДИНИЧНА РОЛКА | 3016
SINGLE WHEEL

МАТЕРИАЛ | Метал
MATERIAL | Metal

ЦВЯТ |
COLOR | Mill finish

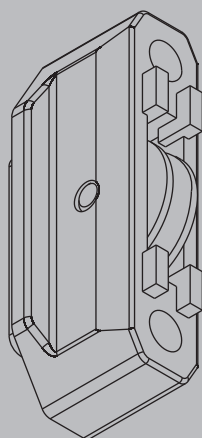

ЕДИНИЧНА РОЛКА ЗА КОМАРНИК | RFS
SINGLE WHEEL FOR FLY-SCR

МАТЕРИАЛ | Пластмаса
MATERIAL | Plastic

ЦВЯТ | Бял
COLOR | white

АКСЕСОАРИ КЪМ ПЛЪЗГАЩА СИСТЕМА S28 / ACCESSORIES FOR SLIDING SYSTEM S28

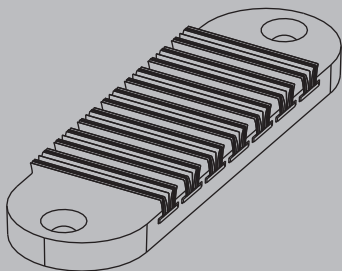

ЧЕТКА ЗА КАСА ПЛЪЗГАНЕ | 3027
CENTRAL SEAL FOR SLIDING FRAME

МАТЕРИАЛ | Пластмаса
MATERIAL | Plastic

ЦВЯТ | Черен
COLOR | Black

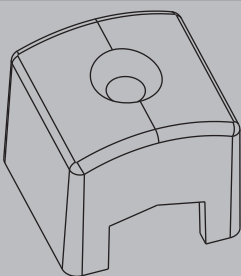

Стопер | 3024
Stopper

МАТЕРИАЛ | Пластмаса
MATERIAL | Plastic

ЦВЯТ | Бял
COLOR | White

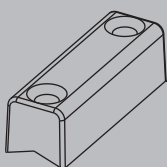

Стопер | 3025
Stopper

МАТЕРИАЛ | Пластмаса
MATERIAL | Plastic

ЦВЯТ | Черен
COLOR | Black

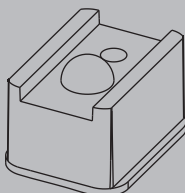

Буфер | 3026
Buffer for sliding

МАТЕРИАЛ | Пластмаса
MATERIAL | Plastic

ЦВЯТ | Черен
COLOR | Black

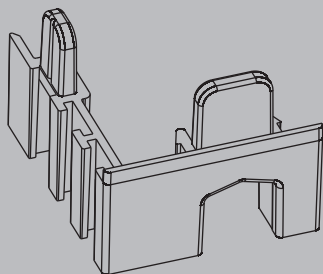

Пластмасова капачка | Pc2805
Plastic cap

МАТЕРИАЛ | Пластмаса
MATERIAL | Plastic

ЦВЯТ | Черен
COLOR | Black

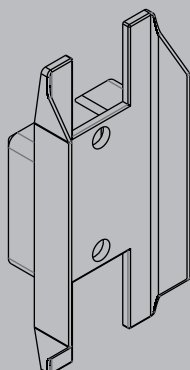

Пластмасова капачка | Pc2813
Plastic cap

МАТЕРИАЛ | Пластмаса
MATERIAL | Plastic

ЦВЯТ | Черен
COLOR | Black